

Bridgepoint Lancer

Operation Manual

Bridgepoint Systems
4282 S 590 W
Salt Lake City, UT 84123
801-261-1282
800-658-5314

Welcome...and congratulations on your purchase of the **LANCER Mobile Cleaning Unit**. This instruction manual has been designed as a guide for operating and servicing your **BRIDGEPOINT LANCER**. **Read this manual completely before installing or operating this unit.**

The **LANCER**, in addition to being a superior carpet cleaner, may also be used for upholstery cleaning.

This unit offers you personal convenience. All of your instrumentation and controls have been positioned to give you easy access for operation and daily maintenance.

Proper operation and service are essential to the efficient functioning of the unit. When maintained correctly, this unit will have a long, trouble-free life.

The service methods described in this manual are explained in such a manner that servicing may be performed accurately and safely. Proper service varies with the choice of procedure, the skill of the mechanic, and the tools or parts available. Before attempting any repair, make certain that you are thoroughly familiar with this equipment and equipped with the proper tools. Any questions pertaining to operating or servicing this unit should be directed to your nearest **BRIDGEPOINT** dealer.

The headings: **CAUTION**, **WARNING**, or **NOTE** are used to warn you that steps must be taken to prevent damage to the unit and/or personal injury. Make certain that you read all instructions entirely before proceeding with the operation of the unit.

THIS UNIT MUST BE INSTALLED BY THE DEALER FROM WHOM YOU PURCHASED IT IN ACCORDANCE WITH PRESCRIBED BRIDGEPOINT INSTALLATION PROCEDURES.

MAKE CERTAIN THAT THE WARRANTY CARD IS FILLED OUT BY THE DISTRIBUTOR FROM WHOM YOU PURCHASED THIS UNIT AND RETURNED TO THE MANUFACTURER!

Please record your unit serial number here for future information or if you should need to contact the factory for any reason.

NOTE:

On units manufactured after September 1996, a "D" will be stamped after the serial number on the serial plate. Make sure this is noted to help identify the unit when ordering parts.

This operation and service manual is written specifically for the **BRIDGEPOINT LANCER MOBILE CLEANING UNIT** which is manufactured by:

PROFESSIONAL CHEMICALS CORPORATION
325 SOUTH PRICE ROAD
CHANDLER, ARIZONA 85224

Information in this document is subject to change without notice and does not represent a commitment on the part of Professional Chemicals Corporation.

All rights reserved. Copyright ©1997 by **Professional Chemicals Corporation**. No part of this work may be reproduced or used in any form or by any means - graphic, electronic, photocopying, taping, or electronic retrieval systems - without the express written permission of Professional Chemicals Corporation.

Published by Professional Chemicals Corporation.

Second printing: January 1997
Printed in USA

BRIDGEPOINT LANCER MANUAL

1 SAFETY

WARNING: For Your Safety!

The following **WARNING LABELS** are found on your **LANCER** console. These labels point out important **Warnings and Cautions** which should be followed at all times. Failure to follow warnings and cautions could result in fatality, personal injury to yourself and/or others, or property damage. Follow these instructions carefully! **DO NOT** remove these labels.

<p>⚠ WARNING</p>  <p>ELECTRICAL SHOCK COULD CAUSE SEVERE BURNS OR INJURY. DO NOT TOUCH ELECTRICAL WIRES OR COMPONENTS WHILE THE ENGINE IS RUNNING. DISCONNECT THE BATTERY BEFORE SERVICING THIS UNIT TO PREVENT ACCIDENTAL STARTING.</p>	<p>⚠ DANGER</p>  <p>WATER UNDER HIGH PRESSURE AT HIGH TEMPERATURE CAN CAUSE BURNS, SEVERE PERSONAL INJURY, OR COULD BE FATAL. SHUT DOWN MACHINE, ALLOW TO COOL DOWN, AND RELIEVE SYSTEM OF ALL PRESSURE BEFORE REMOVING VALVES, CAPS, PLUGS, FITTINGS, FILTERS AND BOLTS.</p>	<p>⚠ WARNING</p>  <p>READ THE OPERATORS MANUAL BEFORE INSTALLING OR STARTING THIS UNIT. FAILURE TO ADHERE TO INSTRUCTION CAN RESULT IN SEVERE PERSONAL INJURY OR COULD BE FATAL. REPLACEMENT MANUALS CAN BE PURCHASED FROM: Professional Chemicals Corporation 325 S. Price Rd. Chandler, AZ, 85224</p>	<p>⚠ WARNING</p>  <p>ROTATING MACHINERY CAN CAUSE INJURY OR COULD BE FATAL. KEEP ALL GUARDS AND SAFETY DEVICES IN PLACE.</p>	<p>CAUTION</p> <p>HOT SURFACE DO NOT TOUCH</p>  <p>IMPORTANT ENGINE INFORMATION</p> <p>THIS ENGINE CONFORMS TO REGIONS CALIFORNIA EMISSION CONTROL REGULATIONS FOR LARGE ENGINES.</p> <p>FAMILY SKH624U1G2RA MODEL NO. CH228S SPEC. NO. 68526 DISPL (CC) 624</p> <p>REFER TO OWNER'S MANUAL FOR SAFETY, MAINTENANCE SPEC'S, AND ADJUSTMENTS.</p> <p>KOHLER engines</p> <p>KOHLER CO. KOHLER, WISCONSIN USA</p> <p>⚠ WARNING ⚠</p> <p>The engine exhaust from this product contains chemicals known to the State of California to cause cancer, birth defects, and other reproductive harm.</p>
<p>ROTATING MACHINERY. WATER UNDER PRESSURE AT HIGH TEMPERATURE. IMPROPER MODIFICATION OF EQUIPMENT CAN CAUSE SEVERE PERSONAL INJURY OR COULD BE FATAL.</p>	<p>⚠ DANGER</p> <p>DO NOT MODIFY UNIT WITHOUT WRITTEN PERMISSION FROM MANUFACTURER</p>	<p>WARNING:</p> <p>OPERATE THIS UNIT AND EQUIPMENT ONLY IN A WELL-VENTILATED AREA. EXHAUST FUMES CONTAIN CARBON MONOXIDE WHICH IS AN ODORLESS AND DEADLY POISON THAT CAN CAUSE SEVERE INJURY OR FATALITY. DO NOT RUN THIS UNIT IN AN ENCLOSED AREA. DO NOT OPERATE THIS UNIT WHERE THE EXHAUST MAY ENTER ANY BUILDING DOORWAY, WINDOW, VENT, OR OPENING OF ANY TYPE.</p>		

Order #48-941212 to get a complete set of decals (safety and instrumentation) for your **Bridgepoint Lancer**. See page A-1 for other unit decals.

The following decal must be placed in a prominent spot on the vehicle that this unit is to be installed in where access is given to operate the unit. See page 20 for suggested locations of this decal.

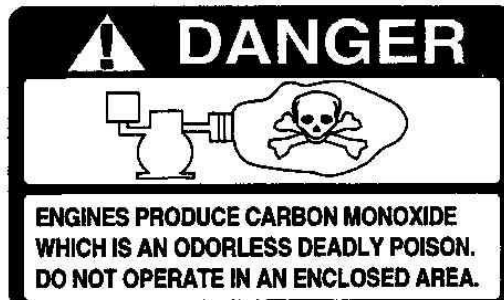

Decal, Carbon Monoxide
Part# 48-941316



This symbol means **WARNING** or **CAUTION**. Failure to follow warnings and cautions could result in fatality, personal injury to yourself and/or others, or property damage. Follow these instructions carefully!



WARNING!

1. *Read the operator's manual before installing or starting this unit. Failure to adhere to instructions can result in severe personal injury or could be fatal.*
 2. *Operate this unit and equipment only in a well-ventilated area. Exhaust fumes contain carbon monoxide which is an odorless and deadly poison that can cause severe injury or fatality. DO NOT run this unit in an enclosed area. DO NOT operate this unit where the exhaust may enter any building doorway, window, vent, or opening of any type.*
 3. *This unit must be operated with the vehicle or trailer doors open in order to ensure adequate engine ventilation.*
 4. *Gasoline is extremely flammable and its vapors can explode if ignited. Store gasoline only in approved containers, in well-ventilated, unoccupied buildings away from sparks or flames. Never carry any gasoline or flammable material in the vehicle. Fumes may accumulate inside the vehicle and ignite, causing an explosion. DO NOT store any type of flammable material in the vehicle.*
 5. *DO NOT operate engine if gasoline is spilled. Avoid creating any ignition until the gasoline has been cleaned up. Never use gasoline as a cleaning agent.*
 6. *DO NOT place hands, feet, hair, and clothing near rotating or moving parts. Avoid any contact with moving parts! Rotating machinery can cause injury or fatality.*
 7. *Never operate this unit without belt guards. The high speed moving parts, such as belts and pulleys, should be avoided while this unit is running. Severe injury, damage, or fatality may result.*
 8. *DO NOT service this unit while it is running. The high-speed mechanical parts as well as high temperature components may result in severe injury or severed limbs.*
 9. *Never touch electrical wires or components while the engine is running. They can be sources of electrical shock.*
 10. *Engine components can get extremely hot from operation. To prevent severe burns, DO NOT touch these areas while the engine is running - or immediately after the engine is turned off.*
 11. *DO NOT touch the exhaust diverter valve while this unit is running. Severe burns may result.*
 12. *Before servicing this unit, allow it to "cool down." This will prevent burns from occurring.*
 13. *Water under high pressure at high temperature can cause burns, severe personal injury, or fatality. Shut down machine, allow to cool down, and relieve system of all pressure before removing valves, caps, plugs, fittings, filters, and bolts.*
 14. *DO NOT leave the vehicle engine running while operating this unit.*
 15. *Dangerous Acid, Explosive Gases! Batteries contain sulfuric acid. To prevent acid burns, avoid contact with skin, eyes and clothing. Batteries produce explosive hydrogen gas while being charged. To prevent a fire or explosion, charge batteries only in well ventilated areas. Keep sparks, open flames, and other sources of ignitions away from the battery at all times. Keep batteries out of the reach of children. Remove all jewelry when servicing batteries.*
- Before disconnecting the negative (-) ground cable, make sure all switches are OFF. If ON, a spark will occur at the ground cable terminal which could cause an explosion if hydrogen gas or gasoline vapors are present. When disconnecting the battery, ALWAYS disconnect the negative (-) terminal FIRST.*

16. DO NOT smoke around the unit. Gas fumes may accumulate and be ignited. The battery is also extremely flammable. This will prevent possible explosions.

17. DO NOT damage the vehicle in any manner during installation. When routing fuel lines **DO NOT** place the hose in any location where damage may occur to the hose or vehicle. Avoid any contact with moving parts, areas of high temperature, brake lines, fuel lines, muffler, catalytic converter, or sharp objects.

18. DO NOT cut or splice any of the vehicle fuel lines during fuel line installation. This may result in fuel leaks and potentially dangerous conditions. There is no fuel solenoid shut off on this unit. Use only the provided abrasion resistant fuel hose for fuel lines. When traversing the vehicle floor with fuel lines, always use a bulkhead adapter. This will prevent leakage and ensure that the hose is not punctured by vehicle vibration abrasion.

19. DO NOT exceed your vehicle's weight limit. The console with waste tank and accessories weighs approximately 886 lbs. Make certain that the vehicle has the correct axle rating. This will prevent unsafe vehicle driving conditions.

20. We require high-back seats on all vehicles in which units are to be installed for head and neck protection. We recommend using a metal partition between the seats and equipment.

21. DO NOT operate this unit without the water supply attached and turned on. The water pump and other vital components may be seriously damaged if this unit is permitted to operate dry without water. This unit is equipped with a low pressure shut-down device. **DO NOT** bypass or operate this unit without the low pressure shut-down switch.

22. Keep your vehicle work area clean. Wands, stair tools, and other accessories must be securely fastened before driving the vehicle. This will prevent damage to yourselves or your equipment in the event of sudden stops.

23. All high pressure hoses must be rated for 3000 PSI at 250°F. Thermoplastic hoses do not meet these specifications and should not be used. Severe burns and injury may result if the hoses do not meet these requirements.

24. Convenience outlet hose is for winterizing kit use only. If used improperly, live steam may escape from this hose, causing it to whip around. Burns or injury may result.

25. Make certain that you receive complete training by the distributor from whom you purchased this unit.

26. This unit uses high pressure and temperature. Improper or irresponsible use may result in serious injury.

27. Do not modify this unit in any manner. Improper modification can cause severe personal injury or fatality.

28. CALIFORNIA PROPOSITION 65
WARNING: Engine exhaust from this product contains chemicals known to the State of California to cause cancer, birth defects, or other reproductive harm.

SPECIFICATIONS:

Engine speed	2800 rpm (high speed in Heat Exchanger position) 1400 rpm (idle speed in Muffler position- Water Pump "OFF")
Water pump rpm	1800 rpm
Vacuum pump rpm	2580 rpm
Water flow rate	4.0 GPM
Water pump pressure	1000 PSI
Vacuum relief valve	14" Hg
Waste tank capacity	66 Gallons (55 Gallons to Shut-Off)
Console weight	702 lbs.
Console weight (with waste tank and accessories)	947 lbs. (1405 lbs if waste tank is full)

TORQUE VALUES

Component	inch/lbs	foot/lbs
Engine hub	264	22
Vacuum pump hub	192	16

JET SIZING

Bridgepoint recommends floor tool tip sizing not exceed a total of ".06".

Example: Tri jet wand uses three 9502 jets. (95° spray angle w/ 02 orifice)
 $02 \times 3 = 06$

When using two floor tools while cleaning with this unit, **Bridgepoint** recommends that each tool tip size does not exceed a total of ".045".

Example: Tri jet wand uses three 95015 jets. (95° spray angle w/ 015 orifice)
 $015 \times 3 = 045$ 045×2 tools = 09

Using larger jet sizes on your Lancer may reduce cleaning temperatures.

Upholstery tool jet size: 80015

Stair tool jet size: 9502

INSTALLATION REQUIREMENTS

Prior to starting the installation, first read the **ENTIRE** "Installation Section" of this manual. Since the **Lancer cleaning unit** (with waste tank and accessories) weighs 947 pounds consider the following recommendations *before* installing this unit.

1. The unit should **not** be mounted in any motor vehicle of less than **3/4 ton capacity**, or a minimum 1 ton capacity if equipped with an auxiliary fresh water tank or tanks.

**CAUTION:**

The unit with waste tank and accessories **must NOT** exceed the vehicle's axle weight limit.

2. If mounting in a trailer, make certain that the trailer is rated for the total weight of the **UNIT AND TRAILER**. Electric or hydraulic brakes should be provided, and a strict compliance to any State and Federal vehicle laws must be maintained.

3. The vehicle tires should have a load rating above the *combined* vehicle and unit weight.

4. We do not recommend using flooring materials that absorb water. This could result in rust and corrosion of the vehicle floor.

5. Padding under rubber floor mats should be removed before installing this unit.

6. We highly recommend using a galvanized drip tray under the console. (#56-501845)

7. If using a trailer, the Lancer console should be positioned so that it balances properly with respect to the axle. Ten percent (10%) of the overall unit weight (without accessories or water) should be on the tongue.

FUEL REQUIREMENTS

Use **unleaded gasoline ONLY**. **DO NOT** use any gasoline additives. We recommend the use of clean, fresh, unleaded gasoline intended for automotive use. High octane gasoline should **NOT** be used with the engine on this unit.

ENGINE OIL REQUIREMENTS

We recommend using the following chart for selecting the proper oil.

Use high-quality detergent oil of API (American Petroleum Institute) service class **SF** or **SG**. Select the viscosity based on the air temperature at the time of operation as shown in the following table:

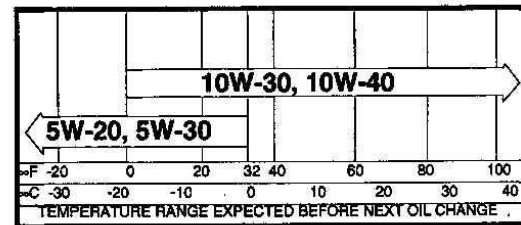
RECOMMENDED SAE VISCOSITY GRADES

NOTE: Using other than service class SF or SG oil or extending oil change intervals longer than recommended can cause engine damage.

CHEMICAL REQUIREMENTS

The **Bridgepoint LANCER**, due to its chemical injection pump design, can be used with a variety of water-diluted chemical compounds (either acid or alkaline), depending on the job to be done. However, to obtain optimum results with this unit, we recommend using the **Bridgepoint** line of chemicals. For information on using the cleaning compounds, contact your nearest **Bridgepoint** distributor.

WATER REQUIREMENTS

Hard water deposits will adversely affect the plumbing and heat exchange systems on this unit.

The map below will give you an idea of where areas of high water hardness may occur. Though any water supply obtained from a well is almost always hard water and a water softener will be needed to protect your equipment.



NOTE:

Equipment malfunction or component failure caused by hard water scaling is NOT covered under the warranty.

If you are operating this unit in an area where the unit will be using water in which the hardness exceeds 3-1/2 grains, we highly recommend a suitable water softener be installed. If using a water softener, it must have a five (5) GPM (or greater) flow capacity without any hose constrictions.

Using a water softener will reduce maintenance and decrease down time caused by hard water scaling. It will also allow cleaning chemicals to be more effective in lower concentrations.

HARD WATER MAP

-  LESS THAN 3.5
-  3.5 TO 7
-  MORE THAN 7



2 RECEIVING YOUR UNIT

This chapter of the manual contains information on receiving your **Bridgepoint LANCER**.

DEALER RESPONSIBILITY

The **Bridgepoint** distributor from whom you purchased this mobile cleaning unit is responsible for the correct installation of this machine and for initial training of your operators and maintenance personnel in the proper operation and maintenance of this unit.

ACCEPTANCE OF SHIPMENT

Every part of your **Bridgepoint LANCER** cleaning unit was carefully checked, tested, and inspected, before it left our manufacturing plant. **Upon receiving the unit, make the following acceptance check:**

1. The unit should not show any outward signs of damage. If damaged, notify the common carrier **IMMEDIATELY**.
2. Check your equipment and packing list. The standard **Bridgepoint LANCER** unit should arrive equipped with the following items (unless otherwise specified) and any optional accessories which were ordered:

EQUIPMENT LIST

- A) **Bridgepoint LANCER console.**
- B) **Operation and service manual with engine, water pump, and vacuum pump manual.**
- C) **Installation bolting kit.**
- D) **Installation mounting plates.**

- E) **Fittings and hoses for standard fuel supply installation.**
- F) **Hose clamps for fuel & vacuum hoses.**
- G) **External fuel pump installation kit.**
- H) **Carpet wand.**
- I) **Waste tank w/float switch.**
- J) **Waste tank filter and strainer basket.**
- K) **100 ft. vacuum hose.**
- L) **1 vacuum hose connector.**
- M) **100 ft. of 1/4" high pressure hose with quick connects.**
- N) **50 ft. water supply hose with quick connects.**

OPTIONAL EQUIPMENT

- O) **Upholstery tool**
- P) **Stair tool**
- Q) **Extra wands and hoses.**
- R) **1992 (or later) Ford fuel line installation kit.**
- S) **Automatic waste pump kit.**
- T) **Galvanized drip tray. Part #56-501845**
- U) **Hose reel**

3 INSTALLATION



WARNING:

All units must be bolted to the floor of the vehicle by a Bridgepoint DISTRIBUTOR.

1. LIFTING THE UNIT ON THE VEHICLE

Since the Bridgepoint LANCER console weighs approximately 702 pounds, we recommend using a fork lift to lift the unit onto the vehicle. Position the forks under the unit from the front and MAKE CERTAIN that the forks are spread to the width of the base.

2. POSITIONING THE UNIT IN VEHICLE

Because vehicles vary in size and openings, individuals have their own preference as to where they want their units installed. We strongly recommend a side door installation for the LANCER and DO NOT recommend a rear door installation.

1. Enough space should be provided to assure adequate engine ventilation and room for service and maintenance.

2. The unit with waste tank and accessories must NOT exceed the vehicle's axle weight limit.

3. DO NOT position the console closer than 12" from the bottom of driver and passenger seats.

NOTE: For individuals who wish to make an engineering layout prior to positioning the unit, refer to page 12, figure 1 for waste tank and console dimensions.

3. BOLTING DOWN THE UNIT AND WASTE TANK

NOTE: When positioning the waste tank with respect to the console, hook up the vacuum hoses to the waste tank. This will ensure that the waste tank is positioned CORRECTLY.

Once the unit and waste tank are positioned in the vehicle in the desired location, you may proceed.



CAUTION:

Before drilling any mounting holes in the vehicle floor, make certain that when drilling, you will not do any damage to the fuel tank, fuel lines, or any vital component which might affect the operation or safety of the vehicle.

1. Using the console and waste tank mounting holes as a template, drill six 13/32" diameter holes for mounting the console and six more 13/32" diameter holes for mounting the waste tank.

2. Using the installation hardware kit:

a) Insert six 3/8-16 x 2" hex head cap screws with flat washers through the mounting holes in the Bridgepoint LANCER console, and six 3/8-16 x 2" hex head cap screws with flat washers through the mounting holes in the waste tank.

b) Install the mounting plates underneath the vehicle floor.

c) Screw the 3/8-16 hex head locknuts on the mounting screws and tighten them until the console and the waste tank are firmly secured to the vehicle floor.

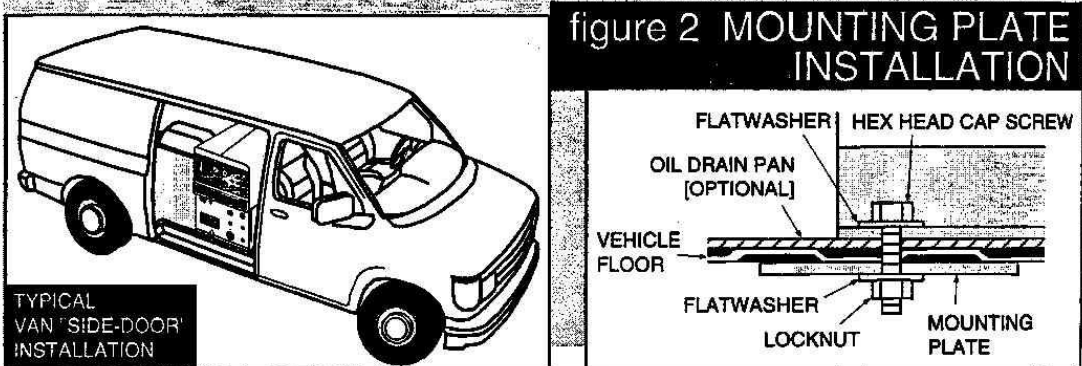
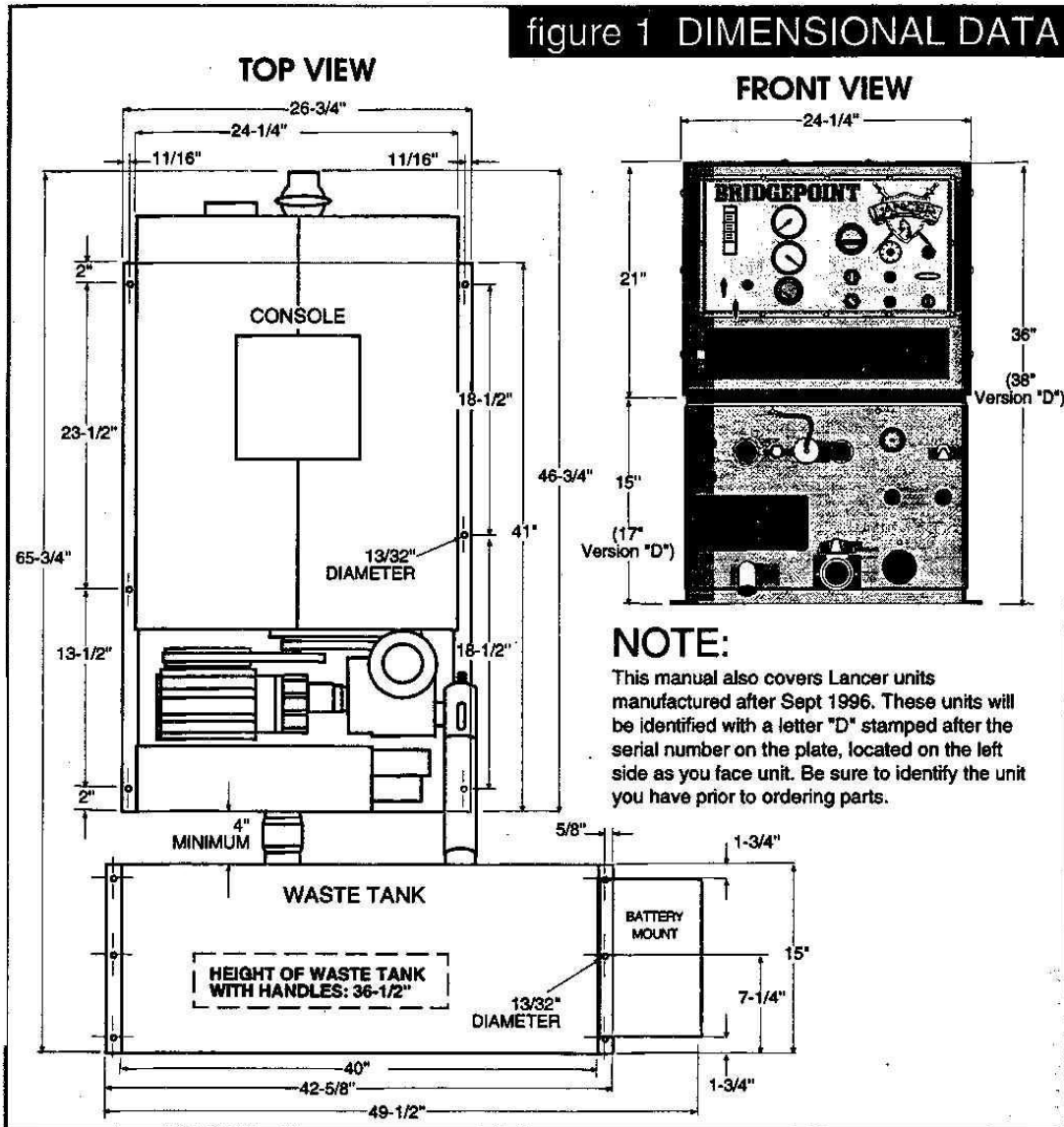

4. INSTALLING FUEL LINE ON VEHICLE

READ THESE INSTRUCTIONS ENTIRELY BEFORE PROCEEDING.



WARNING:

Under NO circumstances should you splice any of the vehicle fuel lines. Severe injury or fatality may result.



CAUTION:

DO NOT damage the vehicle in any manner during installation. When routing fuel lines DO NOT place the hose in any location where damage may occur to the hose or vehicle. Avoid any contact with moving parts, areas of high temperature, brake lines, fuel lines, muffler, catalytic converter, or sharp objects.



WARNING:

Never carry any gasoline or flammable material in the vehicle. NEVER operate this unit off a portable fuel tank. NEVER store any type of flammable material in the vehicle.

The following text applies to vehicles other than 1992 (or later) Fords. See page 15 for 1992 (or later) Ford fuel line installation.

1. Select a location on the vehicle floor to drill a hole for the bulkhead adapter.

This location should be situated in a position that eliminates the possibility of fuel line contact by either the operator(s) or accessories during the working hours or maintenance periods. We supply steel braid fuel hose. Make certain that the hose will reach the location you choose.



CAUTION:

Before drilling the fuel line hole in the vehicle floor, make certain when drilling you will not do any damage to the fuel tank(s), fuel lines, brake lines, or any other vital component which might affect the operation or safety of the vehicle.

2. Drill a 5/8" (.625) diameter hole through the vehicle floor.

3. Install the 1/8" bulkhead adapter by inserting the adapter and tightening the nut on the opposite side of the van floor. (figure 3, p. 14).

4. Attach a 1/8P x 1/4T elbow to the bulkhead adapter on one end (figure 3, p. 14). Attach a 1/8" street elbow and a 1/8P x 5/16H barb fitting to the other end of the bulkhead adapter.

5. Connect one 45-1/2" stainless steel hose from the fuel inlet on the console to the bulkhead adapter.

6. Disconnect from the filler neck the 2 hoses which connect the filler neck and the fuel tank by loosening the hose clamps.

7. Remove the filler neck from the vehicle. Refer to the vehicle manual for instructions and cautions.

8. Select a suitable location for drilling the hole in the filler tank.

The desired location for this hole may vary. It is important that you are able to re-install the filler neck without interference from the fittings which you are adding. Therefore, choose this location wisely before proceeding.

9. Drill a 1/2" diameter hole in the filler neck after you are certain that you have chosen the proper location (figure 5, p. 14).

NOTE: When assembling pipe fittings, Teflon thread sealant must be used.

10. Attach a 1/8" street elbow to one end of the short bulkhead adapter (figure 3, p. 14).

Slide one of the seals over the threads of the bulkhead adapter against the hexagon area.

Next, attach the 25", 36" or 45" stainless steel hose to the 1/8" steel elbow. Choose a length that will reach through the filler neck to the bottom of the fuel tank.

If the selected hose is too short or too long, the unit will run out of fuel before the vehicle fuel tank is empty.

11. Insert the stainless steel hose (bulkhead connector first) into the filler neck until the male threads on the bulkhead connector are protruding through the 1/2" hole.

Slide the other seal over the threads and tighten the hex head nut over the seal (figure 6, p. 14).

Attach the 1/8" street elbow and 1/8P x 5/16H barb fitting to the bulkhead connector, outside the filler neck.

Make certain the fuel hose and fittings remain positioned parallel to the filler neck (figure 5, p. 14).

12. Using a hose clamp, connect one end of the 5/16" fuel hose to the fittings on the outside of the filler neck (figure 5, p. 14).

13. Re-install the filler neck on the vehicle.

14. Insert the filler neck fuel hose into the fuel tank and make certain the end is at the bottom of the tank.

15. Re-connect the 2 hoses which connect the filler neck and the fuel tank. Make certain they are clamped correctly.

16. Route the 5/16" fuel hose underneath the van from the filler neck to the inlet side of the external electric fuel pump. (p. 17). Use the cable ties to secure the hose. Cut off any excess hose and attach to the barb fitting with hose clamp.

17. Attach the remaining hose to the outlet side of the external electric fuel pump with a hose clamp.

18. Using the 5/16" hose, and hose clamps connect the fuel pump box to the bulkhead adapter.



CAUTION:

When routing this hose underneath the vehicle, make certain that you **DO NOT** place the hose in any location where damage may occur to the hose or vehicle. **AVOID** any contact with moving parts, areas of high temperature, muffler, catalytic converter, or sharp objects.

5. INSTALLING THE FUEL TANK AND FUEL LINE (TRAILER)

For trailer installations we recommend the following.

1. Strict compliance to all Federal and State law must be maintained.

2. Provide a safe fuel tank which is manufactured specifically for gasoline, has a proper vented filling cap, and an outlet connection that is the same size as the inlet connection on the unit.

3. DO NOT mount the fuel tank inside an enclosed trailer or van.



WARNING:

Never carry any gasoline or flammable material in the vehicle. NEVER store any type of flammable material in the vehicle.

4. Mount the fuel tank where it will be protected from any vehicle collision.

5. When installing the fuel line from the tank to the unit, use the proper size fuel line.

6. WASTE TANK TO CONSOLE CONNECTION

See illustration on following page.

NOTE: Before connecting any hoses to the waste tanks, make certain the hose clamps are on each hose.

1. Connect the 6" section of 2-1/2" I.D. internal vacuum hose to the 2-1/2" dia. vacuum inlet tube on the console and the 2-1/2" dia. inlet tube on the waste tank. Tighten the hose clamps.
2. Connect the 25" long section of 2-7/8" I.D. internal vacuum hose to the 2-7/8" dia. vacuum outlet tube on the waste tank and to the vacuum pump relief valve on the console. Tighten the hose clamps.
3. Connect the 2" I.D. waste removal hose from the console to the 2" dia. tube at the bottom of the waste tank. Tighten the hose clamps.
4. Connect the 5/16" I.D. water box hose to the barb fitting on the waste tank which is mounted on the outside of the waste tank. Tighten the hose clamps.
5. Connect the console engine shut-off cord to the waste tank level sensor cord.
6. Connect the 3/16 sst hose from the heat bypass valve to the waste tank.

If the unit is equipped with a waste pump-out option, connect the 3/4" waste outlet hose from the outlet assembly on the side of the console to the fitting on the waste tank.

7. BATTERY CONNECTION



WARNING:

Dangerous Acid, Explosive Gases!

Batteries contain sulfuric acid. To prevent acid burns, avoid contact with skin, eyes and clothing. Batteries produce explosive hydrogen gas while being charged. To prevent a fire or explosion, charge batteries only in well-ventilated areas. Keep sparks, open flames, and other sources of ignitions away from the battery at all times. Keep batteries out of the reach of children. Remove all jewelry when servicing batteries.

Before disconnecting the negative (-) ground cable, make sure all switches are OFF. If ON, a spark will occur at the ground cable terminal which could cause an explosion if hydrogen gas or gasoline vapors are present. When disconnecting the battery, ALWAYS disconnect the negative (-) terminal FIRST.

1. Attach the red positive (+) battery cable from the console starter solenoid to the positive (+) terminal on the battery and tighten the holding nut.
2. Next, attach the black negative (-) battery cable from the console ground to the negative (-) terminal on the battery and tighten the holding nut.

BATTERY HOOK-UP

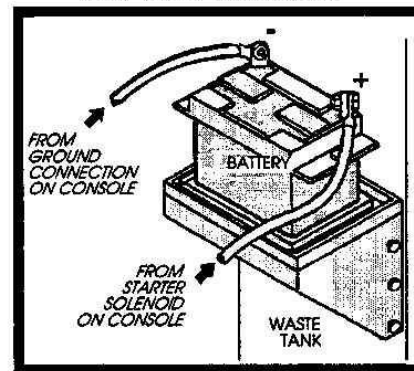

8. FIRE EXTINGUISHER

We recommend that a fire extinguisher, preferably rated for A, B, & C type fires, be installed inside the vehicle.

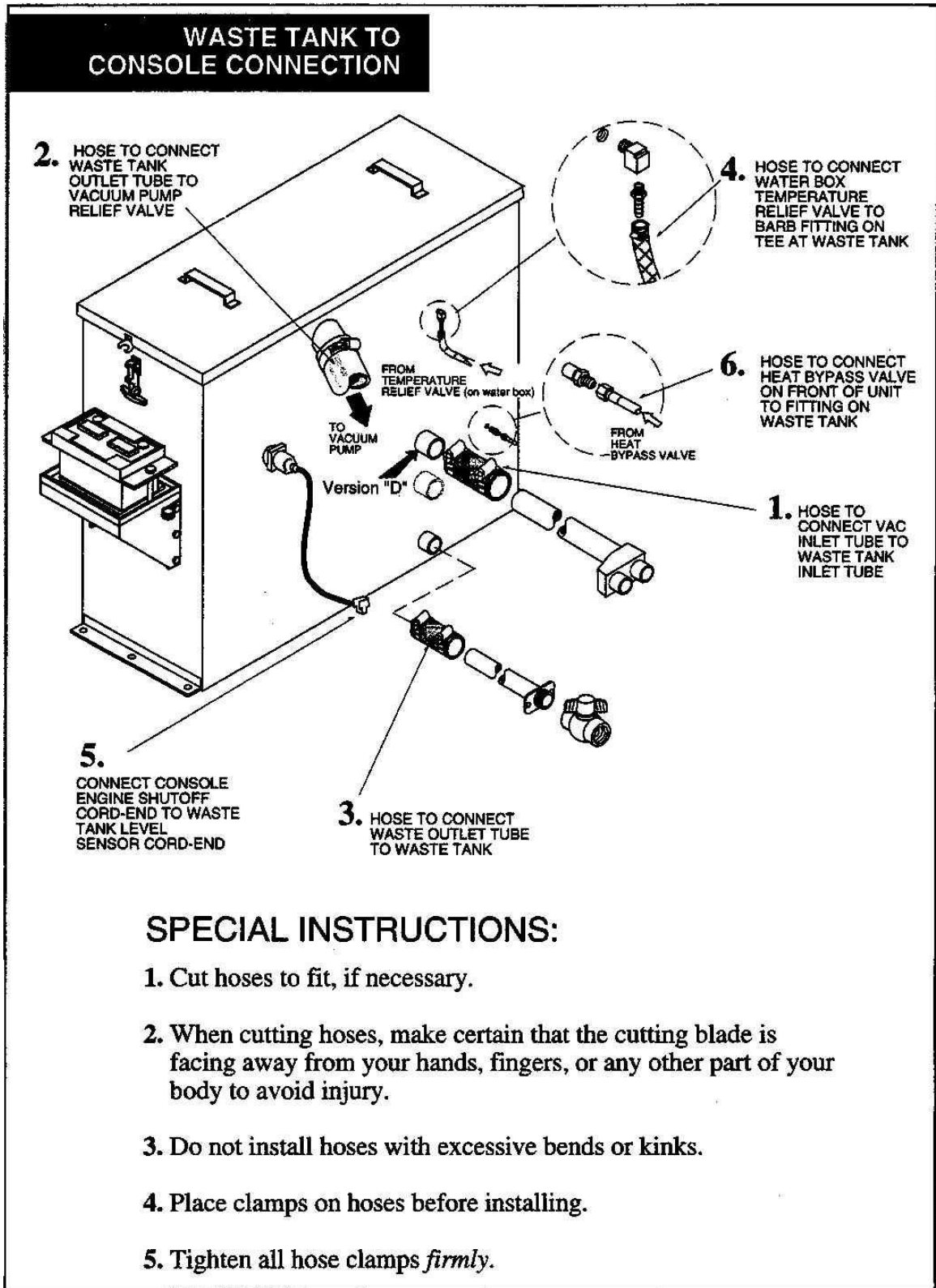

Placement of External Warning Decals

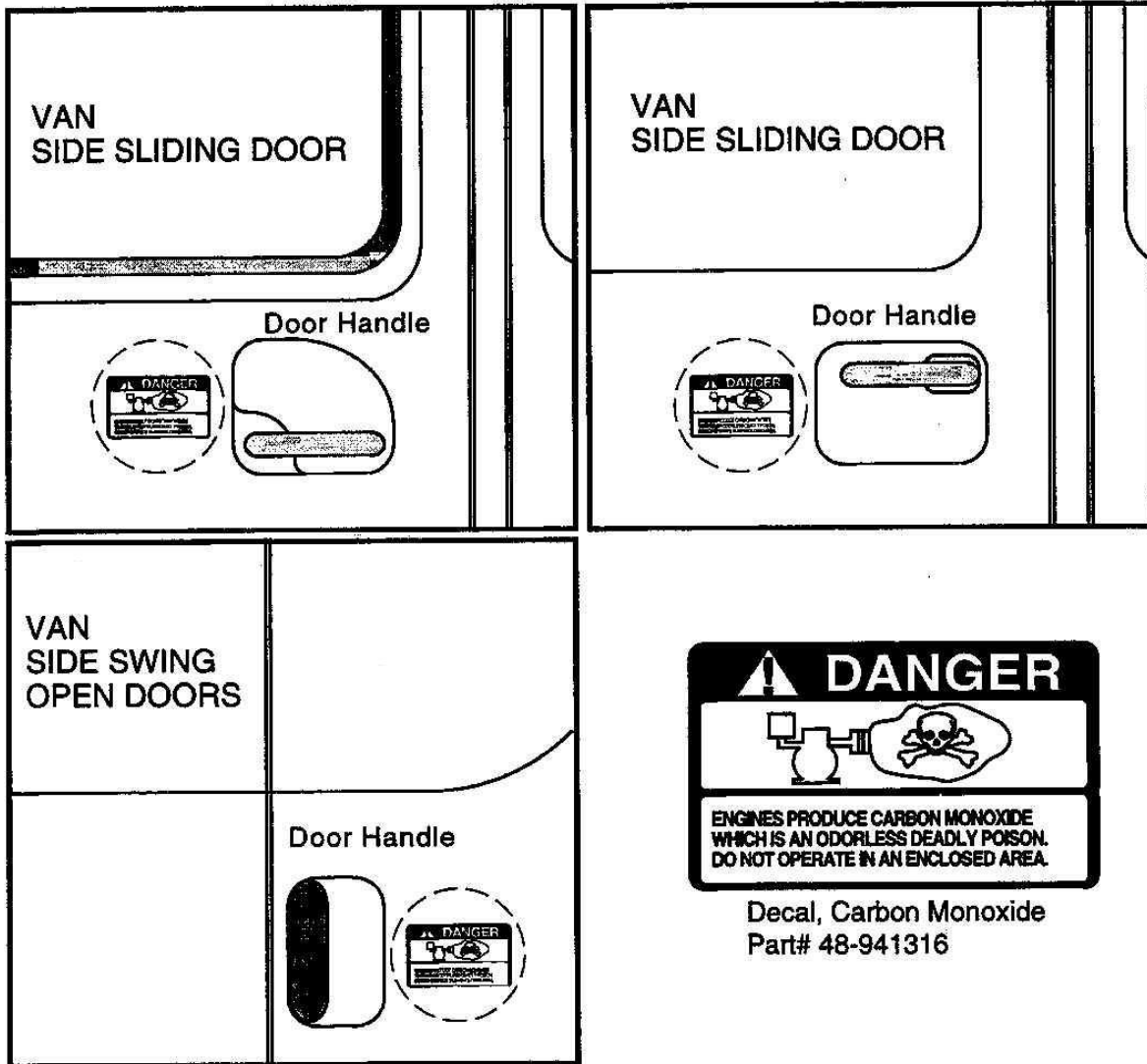

The decal should be placed in a prominent spot on the vehicle where access is given to operate the unit. The illustrations above suggest the location and placement of the decal.

When placing the decal, be sure the area is clean of any dirt and possible wax build-up. Place the decal by starting at one edge and smoothing the decal over to the other edge. This will help eliminate air bubbles and allow the decal to adhere better. After a time the decal may become damaged or worn. If it becomes unreadable, it should be replaced. The part number is shown above to help in ordering.

4 SYSTEMS

This chapter of the operators manual divides the unit up into systems and explains how each system works. Before proceeding into the operational and maintenance section of this manual, we recommend acquiring a basic knowledge of how this unit functions. Read the next section of this manual carefully and completely.

1. WATER PUMPING SYSTEM

See illustrations on following pages.

Cold water enters the console through the water inlet connection located on the lower front panel. The water flows into the water box through a float valve, which shuts off water flow when the box is full.

Water then flows through a strainer into the water pump where it is pressurized. This pressurized water is pumped to the pressure regulator which provides and maintains the desired pressure setting.

Any volume of water not used in the cleaning process flows from the pressure regulator to the vacuum exhaust heat exchangers.

Water flows through two pre-heat radiator-type heat exchangers where heat is transferred from the vacuum pump exhaust. The heated water then returns to the water box.

If the temperature in the water box exceeds 180°F, a temperature relief valve will open and bleed a small amount of hot water into the waste tank, allowing cool water to flow into the water box. When the tool valve is open, water flows through the engine exhaust heat exchanger coils where it is super-heated from engine exhaust flowing through it.

Next the hot water flows through a check valve and Y-strainer to the outlet manifold. This is where chemical injection occurs. The hot solution then flows to the cleaning tool.

Temperature is adjusted primarily using the thermostatic temperature control. This control opens a solenoid valve if the water exceeds the temperature setting. When open, this valve allows hot water to be drawn into the waste tank.

The temperature sensor for this control is located on the manifold next to the solution outlet. From this manifold a small amount of hot water constantly bleeds through the bypass manifold, which contains a small orifice, to the water box.

A heat bypass valve on the lower front panel controls the solution temperature *manually* with a knob adjustment. When open, this valve allows hot water to be drawn into the waste tank through the vacuum inlet tube.

A temperature switch on the heat exchanger outlet will shut down the engine if the water temperature exceeds 285°F. If this occurs, consult the *Troubleshooting* section of this manual to determine the cause of overheating before restarting your unit.

2. HEAT TRANSFER SYSTEM

See illustrations on following pages.

Water is heated through a two stage heat exchange system which utilizes engine exhaust and vacuum pump exhaust.

Water flows through an inlet hose to the water box and then to the water pump where it is pressurized. It then travels to the pressure regulator manifold. This manifold contains a nitrogen-charged accumulator which helps reduce pressure fluctuations and dampen water pump pulsations. This manifold also contains a low-pressure switch and a high-pressure switch. These switches will shut the unit down if the pressure drops below 50 PSI or exceeds 1200 PSI.

Any volume of pressurized water not used in the cleaning process bypasses from the pressure regulator manifold to the vacuum exhaust heat exchanger.

The vacuum exhaust heat exchanger utilizes vacuum pump exhaust as it leaves the vacuum pump. The warm air flows through two radiator-type heat exchangers prior to discharging out to the atmosphere. The water is heated as it flows through these heat exchangers. From the vacuum exhaust heat exchanger, the warm water flows to the water box.

The primary heat exchanger is an engine exhaust chamber containing a stainless steel heating coil. Water flows through the coil and is heated by the engine exhaust as it leaves the engine. The water, still under pressure and hot, is piped to the outlet manifold where chemical is injected and the mixture flows to the cleaning tool.

When the tool valve is open, the water flows through the engine exhaust heat exchanger where it is super-heated by extremely hot engine exhaust.

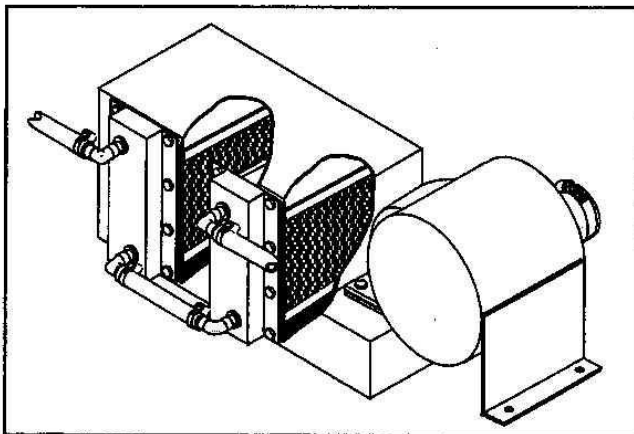

**VACUUM EXHAUST
HEAT EXCHANGER**

**CATALYTIC
ENGINE EXHAUST
HEAT EXCHANGER**

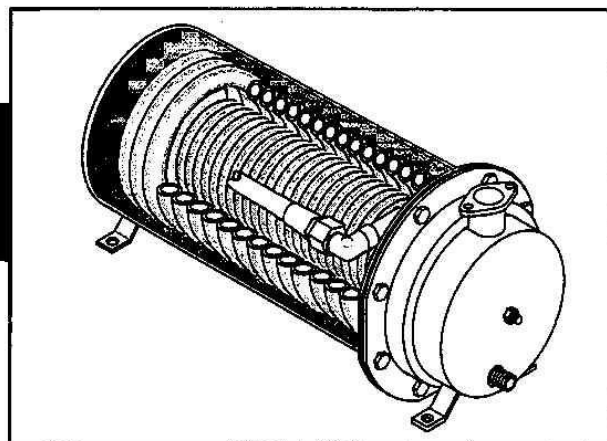

HEAT TRANSFER & WATER PUMPING SYSTEM

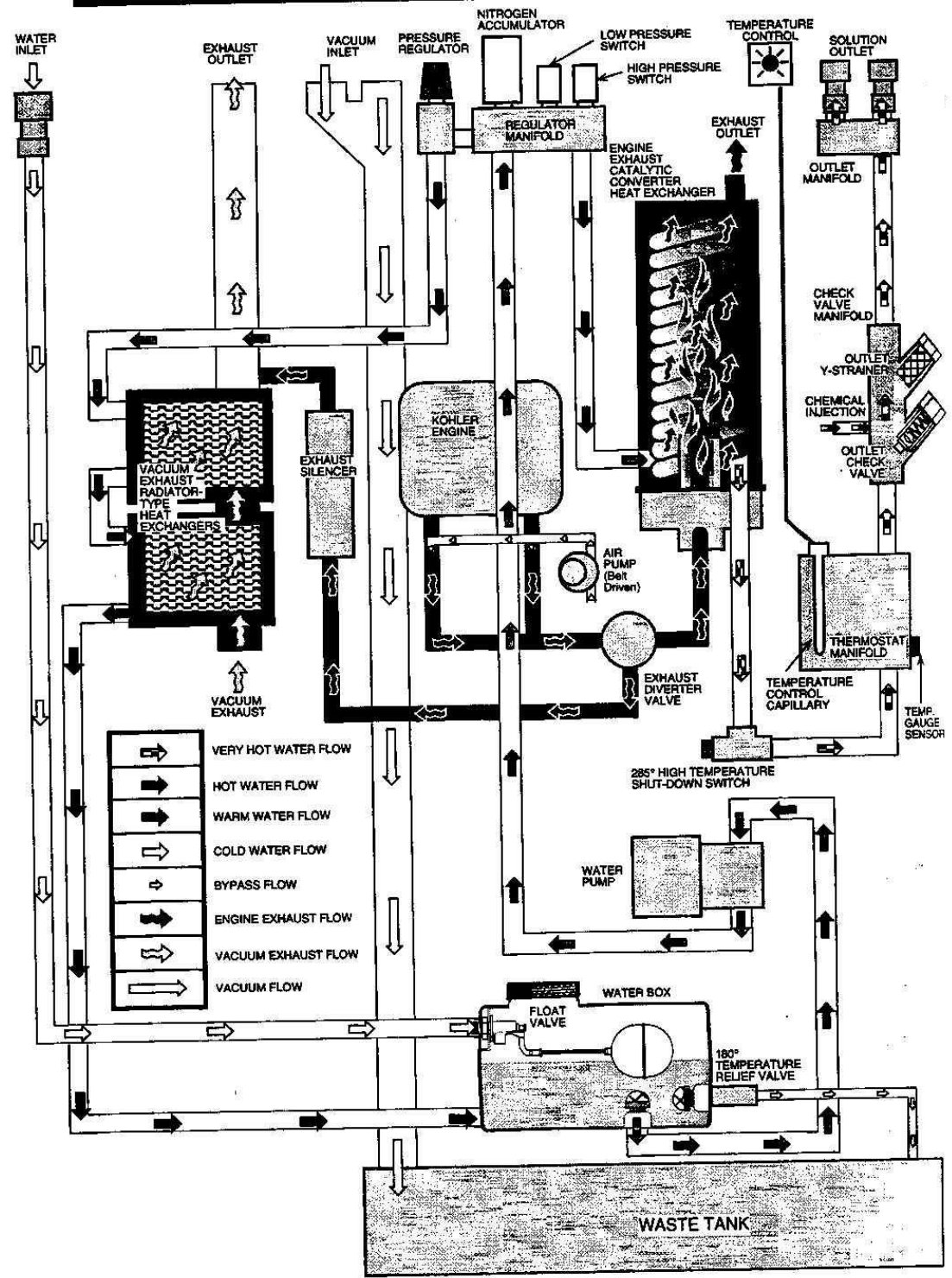

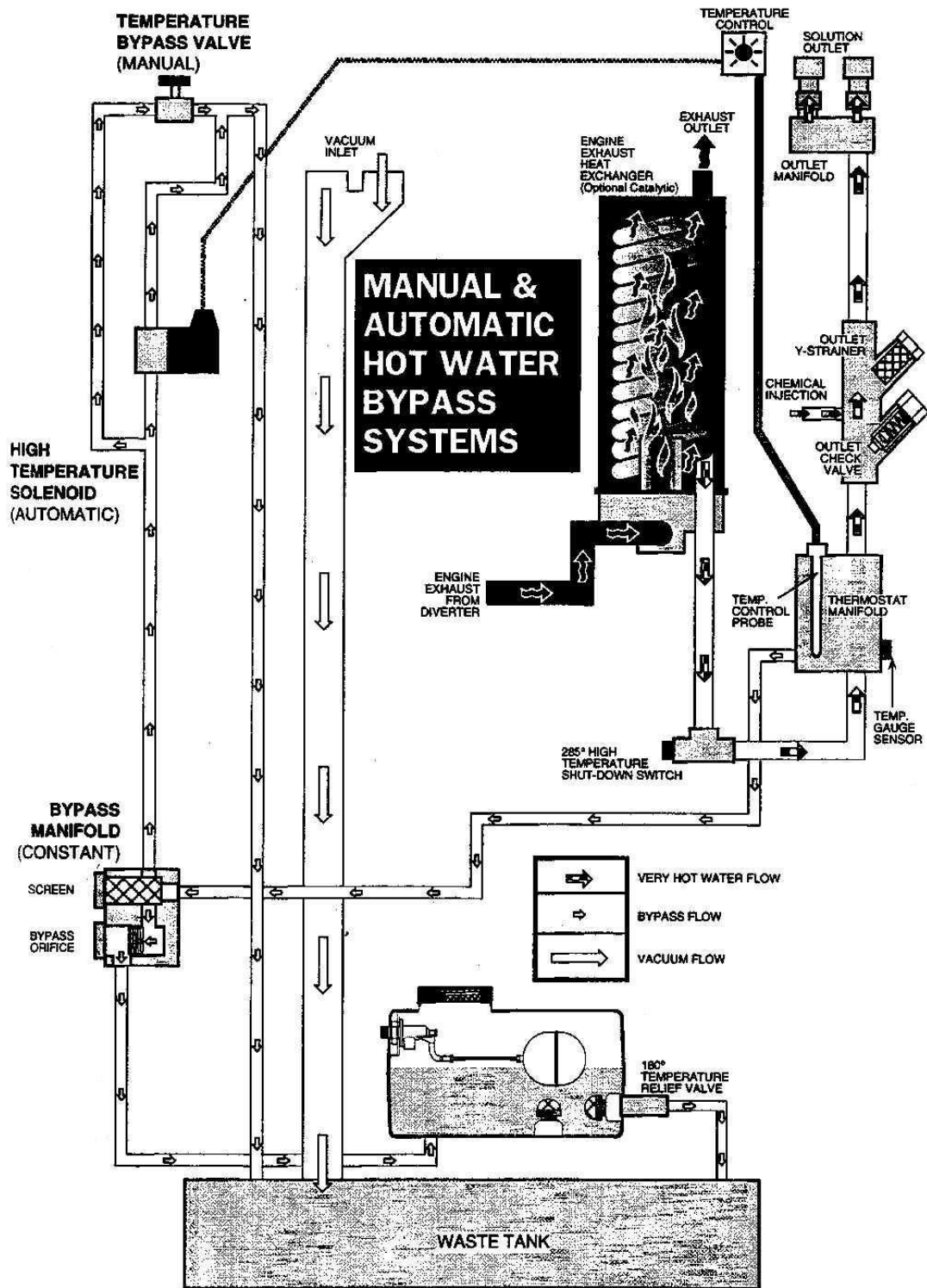

3. VACUUM SYSTEM

Vacuum flow begins at the cleaning tool, with air and spent chemicals being drawn into the vacuum inlet at the front of the console.

The mixture then flows through a strainer basket in the waste tank. A 100 mesh filter and relief valve have been provided for vacuum pump protection.

The air then flows into the vacuum pump.

The vacuum pump is belt-driven by the engine.

The air is discharged from the vacuum pump through the stage one heat exchangers where the heated vacuum exhaust blows across two radiator-type heat exchangers before discharging into the atmosphere.

A level sensor switch located near the top of the waste tank will shut the unit down before the waste tank reaches its full capacity. This protects the vacuum pump from water damage.



CAUTION:

Use of a DEFOAMER will help prevent damage to the unit by a build-up of foam in the waste tank, which may be caused by some chemicals. (Foam build-up will not activate float switches)

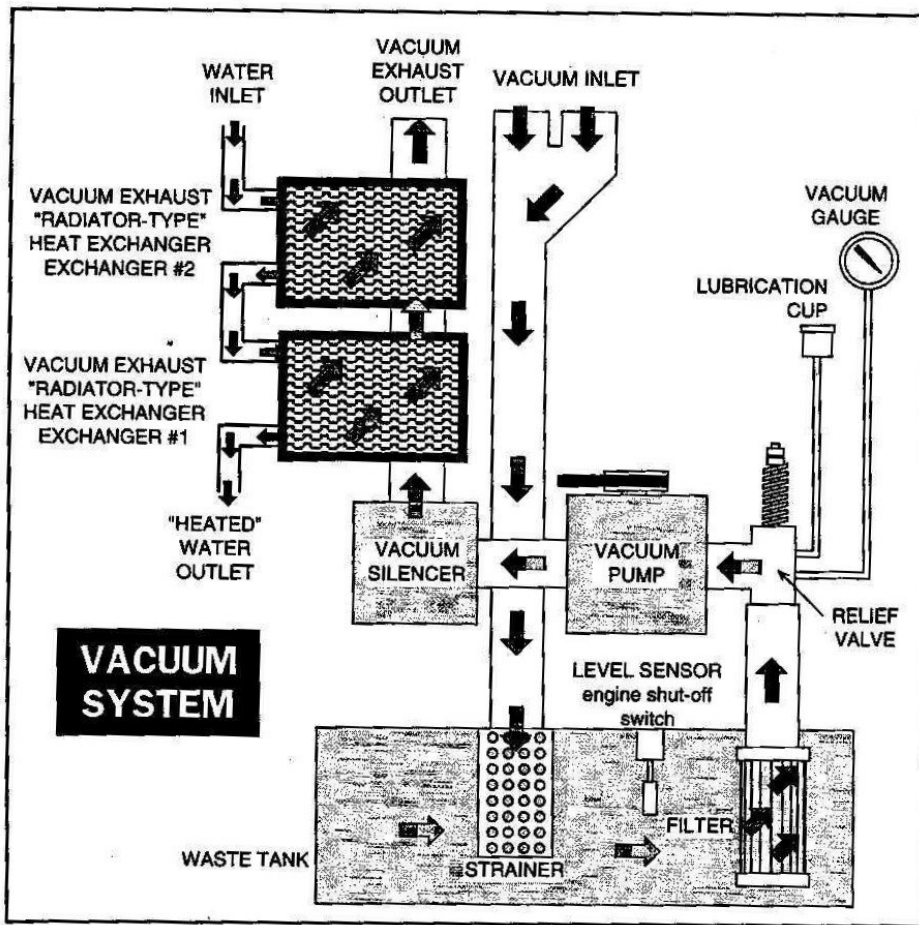

4. CHEMICAL PUMPING SYSTEM

The chemical is drawn from the chemical container through a strainer into a chemical selection valve and then into the flow meter. The flow meter indicates the rate of chemical flow.

NOTE: This unit features a chemical selector valve below the chemical prime and metering valves that allows you to select between two separate chemical containers. The valve must be positioned to one side or other for the chemical system to function properly.

The chemical then flows through a check valve into a pulse-powered chemical pump.

Next, the chemical pump injects the chemical through a check valve to the 3-way chemical prime valve on the control panel. This valve may turn the chemical flow ON (CHEMICAL) OFF or PRIME the chemical pump.

The chemical then flows through a metering valve to the solution outlet. This valve controls the rate of flow of chemical injection into the cleaning solution which is indicated on the flow meter.

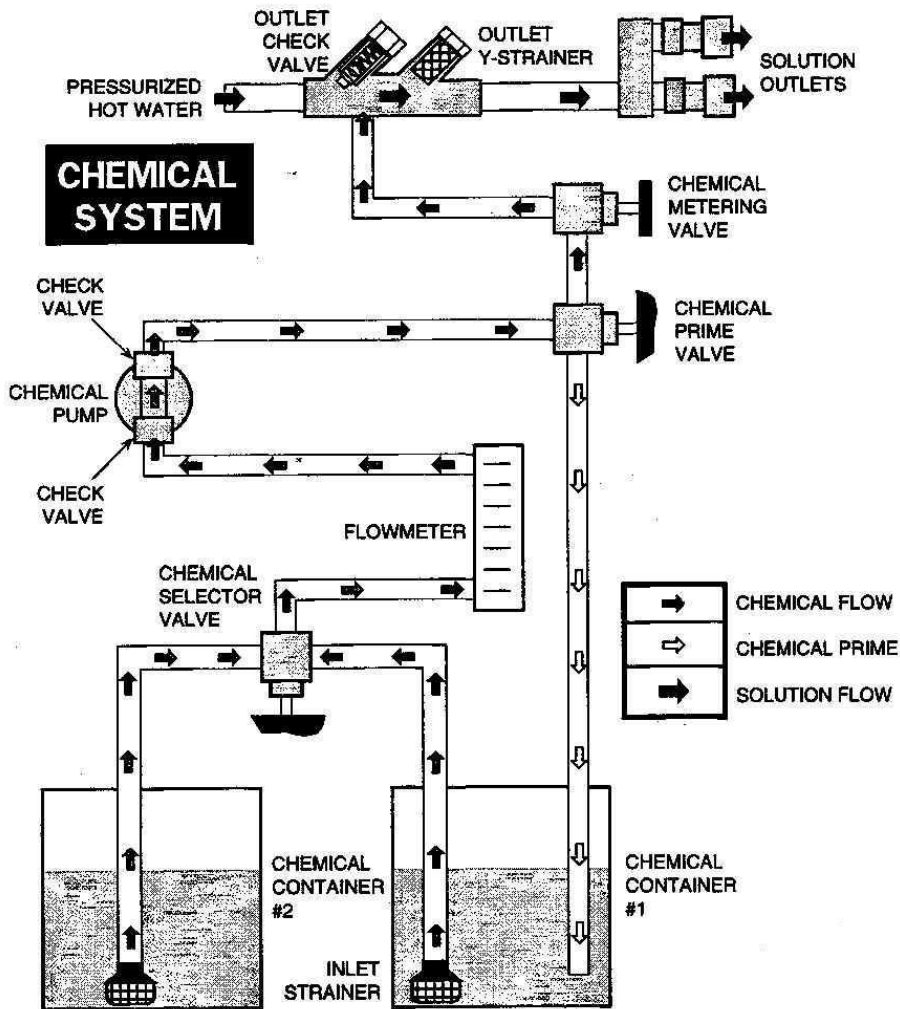

5 OPERATION

This chapter of the operators manual explains how to prepare, start, operate, shut down, and daily maintain the **Bridgepoint LANCER** cleaning unit. Operation of the Lancer is simple. However, only trained personnel should proceed.



CAUTION:

Operate this unit and equipment only in a well-ventilated area. Exhaust fumes contain carbon monoxide which is an odorless and deadly poison that can cause severe injury or fatality. **DO NOT** operate this unit where the exhaust may enter any building doorway, window, vent, or opening of any type.

1. CHECK FOR ADEQUATE FUEL

Check the fuel tank to be certain there is adequate fuel to complete the job. This unit uses approximately 1.15 gallon per hour at the cleaning speed which is full RPM.

2. REMOVE TOOLS FROM VEHICLE

Remove any tools or hoses from the van which you will require.

3. WATER SUPPLY CONNECTION

NOTE: Before connecting your water hose to the supply faucet, flush out the faucet until the water is free of any debris. Flush out any debris which may be in your water inlet hose.

1. Connect the **water supply hose** to the **water inlet** quick-connect at the front of the unit. Connect the hose to the water supply faucet.

NOTE: Never use your waste pump outlet hose as a water inlet hose. Use **ONLY** clean hoses for water inlet.

2. Turn the **water supply faucet on**. The water will fill the water box.

4. HIGH PRESSURE HOSE

Connect the **pressure hose** to the **outlet connection** at the front of the unit. Connect the **cleaning tool** to the **pressure hose**.

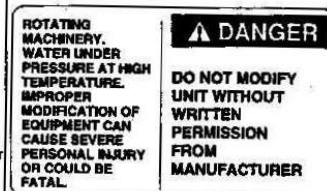

5. VACUUM HOSE

Connect the **vacuum hose** to the **vacuum inlet** connection at the front of the unit. Connect the other end of the **vacuum hose** to the **cleaning tool**.

6. JET SIZING

Bridgepoint recommends **floor tool** tip sizing not exceed a total of "06".

Example: Tri jet wand uses three 9502 jets. (95° spray angle w/ 02 orifice)

$$02 \times 3 = 06$$

When using two floor tools while cleaning with this unit, **Bridgepoint** recommends that each tool tip size does not exceed a total of ".045".

Example: Tri jet wand uses three 95015 jets.

$$015 \times 3 = 045 \dots\dots 045 \times 2 \text{ tools} = 09$$

Using larger jet sizes on your Lancer may reduce cleaning temperatures.

Upholstery tool jet size: 80015
Stair tool jet size: 9502

INSTRUMENTATION

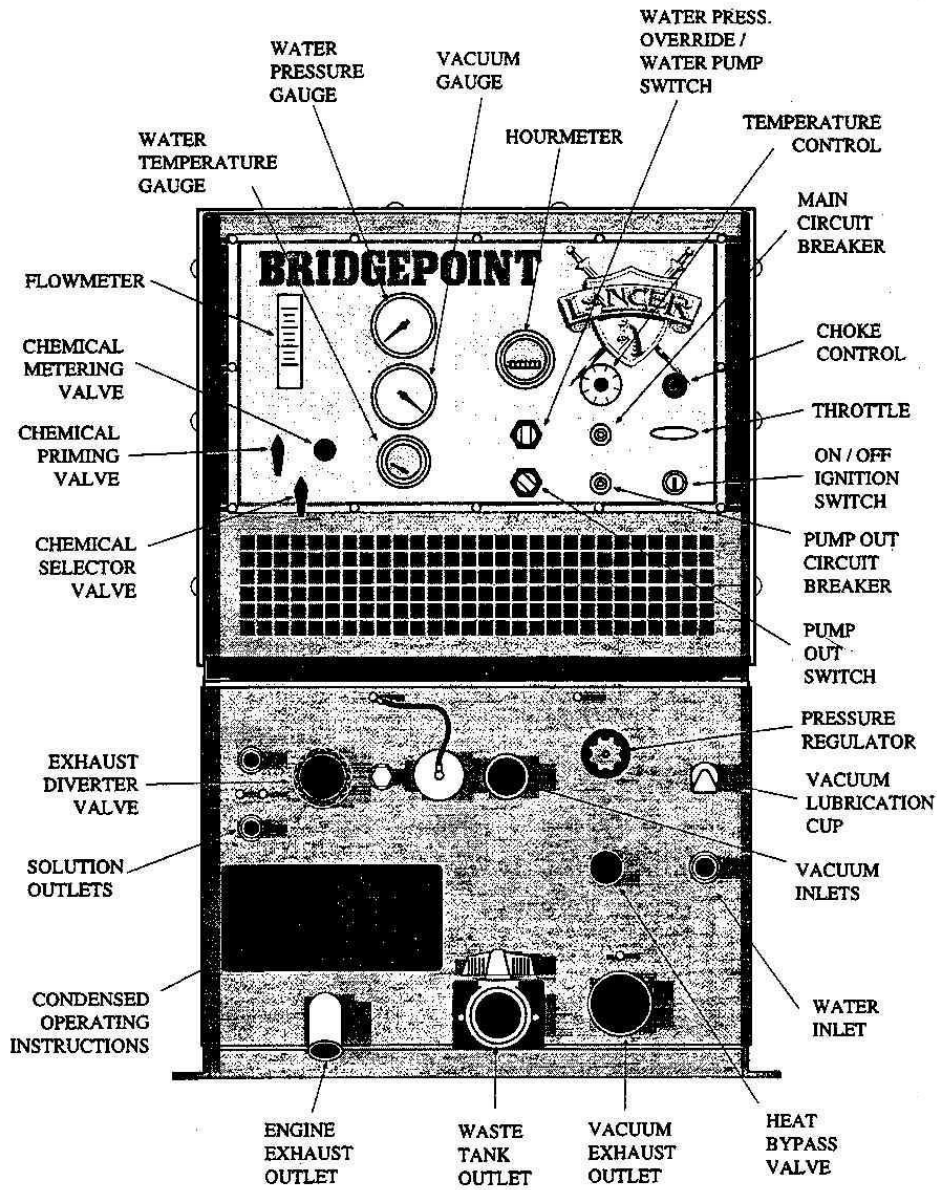

6. STARTING THE UNIT (CLEANING MODE)

1. Set the exhaust diverter valve to the **HEAT EXCHANGER** position. The diverter valve microswitch will automatically turn **ON** the water pump.
2. Set the **temperature control** on the control panel to the desired cleaning temperature. The thermostatic temperature control will allow you to increase or decrease the solution temperature automatically. Simply turn the **control knob** to the desired temperature setting.
3. Close the **heat bypass valve** by turning the knob clockwise. **DO NOT** over tighten.

The **heat bypass valve** allows you to decrease the solution temperature **manually**. Opening the valve (counter clockwise) decreases the temperature by allowing hot water to bypass to the waste tank.



CAUTION:

DO NOT operate this unit without constant water flowing into the console.

The water **low-pressure switch** will automatically shut this unit down if the water pressure in the system drops below 50 PSI.

The water **high-pressure switch** will automatically shut this unit down if the water pressure in the system exceeds 1200 PSI.

Before proceeding, be certain that the control panel indicators are at the following settings:

Engine ---IDLE (Throttle In)
Engine choke - PULL OUT

NOTE: It will **not** be necessary to pull the choke out if the engine is already warmed up.

4. Turn the **ignition switch** to the **START** position while holding the **water pump switch** to the left (override position). The engine will start. Continue to hold the switch in override position until pressure is indicated on the pressure gauge.

NOTE: If your unit fails to build water pressure after 15 seconds, check for adequate water supply. If necessary, see **Loss of Water Pump pressure** in the troubleshooting section of this manual.

5. After starting the engine, push the **choke in**. After the engine has warmed up, pull the **throttle** all the way out and turn it clockwise to lock it in the full throttle position.

Allow adequate time for the your unit to warm up before beginning the cleaning operation.
-approximately 5-15 minutes.

7. PRIMING THE CHEMICAL PUMP

NOTE: Bridgepoint recommends that the **chemical pump be primed whenever the water pump is ON**. This will eliminate possible pressure fluctuations and water pump pulsations related to a dry chemical pump.

1. Place the **chemical inlet tube** and the **chemical prime tube** into the chemical container.

NOTE: When placing the **chemical inlet tube** into the **chemical container**, make certain that it stays fully submerged since the chemical pump will **NOT** function if air is allowed to enter the inlet line. **DO NOT** operate the chemical pump without the inlet strainer properly installed.

2. Turn the **chemical selector valve** on the control panel to the **PRIME** position. The chemical will then flow from the chemical container through the chemical prime tube.

If the chemical does **not** flow, then:

a) Put the **chemical prime tube** into the **vacuum inlet** on the front of the unit and seal it off, the vacuum will quickly pull chemical from the chemical container. when the chemical starts to flow, place the **chemical prime tube** back into the container.

b) Once continuous chemical flow without air bubbles has been achieved, turn the **chemical selector valve** from **PRIME** to **ON (CHEMICAL)**. With the **cleaning tool valve** open, observe the **flow meter** and adjust the **chemical metering valve** until the desired rate of chemical flow is obtained. (the **chemical metering valve** is located on the control panel below the flow meter).

8. WASTE PUMP

If your unit is equipped with an **automatic waste pump**, connect one end of a garden hose to the **pump-out connection** on the console and the other end to an **appropriate waste disposal**.

Turn the **pump out switch** on the control panel to the **ON position**. The waste pump will operate automatically throughout the cleaning operation.

We recommend that you use a 3/4" I.D. water hose as a waste pump outlet hose. **DO NOT** use a hose smaller than 5/8" I.D.

Never use your automatic waste pump outlet hose as a water inlet hose. **Cut the end off the hose that does not connect to the unit to prevent this from happening.**



WARNING!

NEVER dispose of waste in storm drains, water ways, or on ground areas. Always dispose of waste in accordance with Local, State, or Federal law.

9. OPERATION

Once you have completed steps 1 through 8, proceed with the cleaning operation. Your unit should be in the full throttle position when cleaning or extracting. A **float switch** located inside the waste tank will automatically shut down the unit when it reaches its full capacity. When this occurs, empty the waste tank before continuing.

EXHAUST DIVERTER VALVE

The **exhaust diverter valve** allows you to direct exhaust through either:

A) The **exhaust HEAT EXCHANGER**
– for high-temperature cleaning.....or

B) Through the **exhaust MUFFLER**
– for extraction, such as flood restoration.

When the **exhaust diverter valve** is in the **MUFFLER** position, a microswitch automatically shuts off the water pump. This protects the water pump from excessive heat during flood restoration work.

An **override switch** on the control panel will enable you to turn the water pump **ON**, when in the **MUFFLER** position.

10. CLEANING

Observe the following guidelines, while cleaning:

1. Before proceeding make sure the nozzle is functioning properly.

a. To check, hold the wand about one foot above the surface to be cleaned and open the wand valve. A full spray should be observed from the cleaning nozzle.

b. If the nozzle is not showing a full spray pattern, adjust nozzle for proper pattern, clean, or replace nozzle.

2. Normally, chemical is applied on the push stroke of the wand when cleaning, and vacuuming is done on the pull stroke. For heavily soiled carpets the wand may be used in a scrubbing manner, applying chemical in both push and pull strokes. Always finish up an area with a vacuum pull stroke.

3. When cleaning, keep the working opening (mouth) flat on the surface being cleaned. Keep the wand moving when the valve is open.

4. The unit will automatically shut-down when the waste tank is full. This will prevent water being drawn into the vacuum pump. If shut-down occurs, empty the waste tank before proceeding.



WARNING!

NEVER dispose of waste in storm drains, water ways, or on ground areas. Always dispose of waste in accordance with Local, State, or Federal law.

11. UPHOLSTERY CLEANING

Upholstery Tool Part #60-950422

1. Since this tool has a lower flow rate and smaller orifice, operate the unit with the diverter valve in the **MUFFLER** position and the water pump switch **ON**. This will prevent excessive heat in the water pumping system and limit bypass flow into the waste tank while cleaning upholstery.

2. To further reduce heat, slightly open the heat bypass valve located below the control panel.

NOTE: If the unit is equipped, use the automatic waste pump-out system. This will compensate for the extra bypass flow to the waste tank.

3. Use one (1) "80015" spray tip in either tool.

4. Pressure adjustment below 300 PSI should be made at the tool itself, by using the adjusting knob located on the valve.

12. STAIR TOOL CLEANING

1. Turn the **diverter valve** to the **HEAT EXCHANGER** position. Set the **temperature control** to the desired temperature setting.

2. To further reduce heat, slightly open the **heat bypass valve** located below the control panel.

NOTE: If your unit is equipped, turn the automatic waste pump **ON**. This will compensate for the extra bypass flow into the waste tank.

3. Use one (1) "9502" spray tip in your stair tool.

13. FLOOD RESTORATION



CAUTION:

A water supply should be connected to the unit to prevent overheating. Never allow the system to run dry.

1. Set the **temperature control** on the control panel to 200° and close the **heat bypass valve** by turning the knob clockwise, **DO NOT** over tighten. This will limit the bypass flow to the waste tank.

2. During flood restoration, turn the **diverter valve** to **MUFFLER** position. Make certain that the water pump override switch is "ON", with the pressure set at 400 to 500 PSI.

14. SHUTDOWN AND DAILY MAINTENANCE

1. Run fresh water through the **chemical injection system** to flush out chemicals.

2. We recommend removing as much moisture from your **vacuum hoses** as is reasonable. This

will prevent spillage of solution in your vehicle when replacing hoses.

3. Position the throttle control to approximately 3/4 of the way out, but no less than 1/2 out.

4. Disconnect the **vacuum hoses** from the unit.

5. Open the **heat bypass valve** two (2) turns and allow unit to cool down to 180° or less, and then close valve completely. **DO NOT** over tighten valve.

6. Push the throttle all the way in to idle and allow the unit to run for **1 minute** in order to remove all moisture from the **vacuum pump**.

NOTE: If finishing for the day:

Pull throttle all the way out, plug the **vacuum inlet** and spray WD-40 (or equivalent) into the **vacuum lubrication cup** (located at front of console). This will lubricate the **vacuum pump**. Push the throttle back to idle and continue to #7.

7. Turn the **ignition switch** to the "OFF" position.

8. Turn the **water supply faucet** off. Bleed the pressure out of the **water supply hose** by loosening the hose at the water supply. Unhook **water supply hose** and store in vehicle.

9. Relieve pressure from the **cleaning tools and pressure hoses** by activating the valve on the tool. Disconnect the **tools and pressure hoses** from the unit and store away all equipment.

10. Drain the **waste tank** and dispose of waste in a proper manner.



WARNING!

NEVER dispose of waste in storm drains, water ways, or on ground areas. Always dispose of waste in accordance with Local, State, or Federal law.

11. Remove the **strainer basket** from the waste tank, clean out any accumulated debris, and re-install. Inspect the **vacuum inlet filter** inside the waste tank. If there is any lint or debris, remove and clean filter.

NOTE: When removing the **vacuum inlet filter**, grip the plastic hexagonal section of filter. Grasping filter by the screen may collapse or ruin the filter. Re-install the filter

hand-tight. **NEVER operate this unit with this filter removed, damaged or improperly installed.**

NOTE: When replacing this filter, we recommend using the stainless steel filter (#14-806518) only. This will prevent rust and corrosion from entering the vacuum system.

12. At the end of your work day, rinse out the waste tank with fresh water. DUO Deodorizer may be added to the waste tank to inhibit the growth of bacteria.

13. Clean the unit, tools, hoses, van interior, etc., as needed. Inspect ALL equipment for any damage, wear, leaks, etc.

15. FREEZING PROTECTION



WARNING:

If the unit is exposed to freezing weather the water in the unit may freeze causing **SERIOUS DAMAGE** to the unit. To avoid this, the following is recommended during the cold weather season:

When the unit is not in use, always park it in a heated building. If a heated building is not available, we recommend that you winterize the unit with anti-freeze. At present, it is only possible to winterize units which do not have an auxiliary water tank. Units with auxiliary water tanks must be stored in a heated building when not in use.

While in operation, avoid long shutdowns as unit provides heat while running. Shut it down just prior to leaving for the next job.

ADDING ANTI-FREEZE TO YOUR UNIT:

1. Shut off the water supply. Disconnect the water inlet hose from the front of your console.
2. Connect all high pressure hoses and tools that may contain water in the lines, hoses, or valves.
3. Start your unit with the exhaust diverter valve in the **HEAT EXCHANGER** position.
4. Open the tool valve until the low pressure switch shuts the unit down.
5. Fill the water box with approximately two gallons of 100% glycol base anti-freeze.

6. Turn the diverter valve to the **MUFFLER** position. Close the heat bypass valve by turning the knob all the way clockwise.

7. Turn the water pressure override switch to the override position and start your unit. Turn the water pump switch ON.

8. Open the tool valve until anti-freeze begins to come out of the tool. Recover ALL anti-freeze that comes out of the tools in an approved container.

We strongly recommend that you re-cycle and re-use the anti-freeze.

Repeat this procedure with all the remaining tools. After all tools and pressure hoses have been filled with anti-freeze, disconnect and store them.

9. Turn the water pump switch OFF. Attach the loop hose with attachment to the solution outlet connection and the water inlet connection. Turn the water pump switch ON.

Allow the unit to run for approximately 3 minutes with the loop hose attached.

10. Prime the chemical system with anti-freeze. Insert the chemical inlet and prime tubes in to the anti-freeze container. Turn the chemical valve to **PRIME** until antifreeze begins to flow out of the prime hose. Turn the valve to the **ON (CHEMICAL)** position, making certain that the flow meter indicates flow. Make certain that all anti-freeze drains out of the chemical hose into an approved container.

After 20 seconds, turn the chemical valve to the "OFF" position.

#10-805380

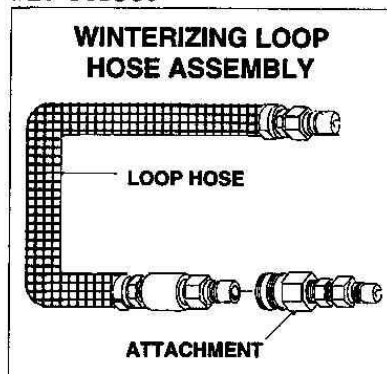

11. Open the heat bypass valve by turning the knob counterclockwise. After 10 seconds, close the heat bypass valve.

Turn the temperature control on the control panel to 50° for 10 seconds.

After completing these procedures, shut the unit down. The unit is now "winterized".

REMOVING ANTI-FREEZE FROM THE UNIT:

1. Connect one end of the loop hose to the solution outlet connection. Place the other end of the loop hose in to an approved container.
2. Start the unit. The anti-freeze will flow in to the container until the low pressure switch shuts the unit down.
3. Fill the water box with fresh water and repeat step #2.
4. Connect the water inlet hose to the water inlet connection on the console. Turn the water supply on.
5. Connect all solution hoses and any tools which require purging of anti-freeze to the solution outlet connection(s).
6. Open the tool valves and drain the anti-freeze into an approved container until anti-freeze is purged from the tools and hoses until the flow is clear.
7. Place the chemical prime hose into the approved container. Submerge the chemical inlet hose in water. Turn the chemical valve to the **PRIME** position until clear water comes through the prime hose, and then remove prime hose from container.

Turn chemical valve to **ON (CHEMICAL)** position. This will allow water to flow into the other side of the system.

Once all of the anti-freeze is removed, the unit is ready to use.

Eventually, the anti-freeze in the storage container will become diluted with water. If the anti-freeze level drops below 50%, dispose of it and start with fresh 100% anti-freeze.



WARNING:

When disposing of used anti-freeze, observe local laws and regulations. Where permitted, we recommend disposal in sanitary sewer systems. Do not drain on to the ground or into storm drainage systems.

Illustrated Parts Listings

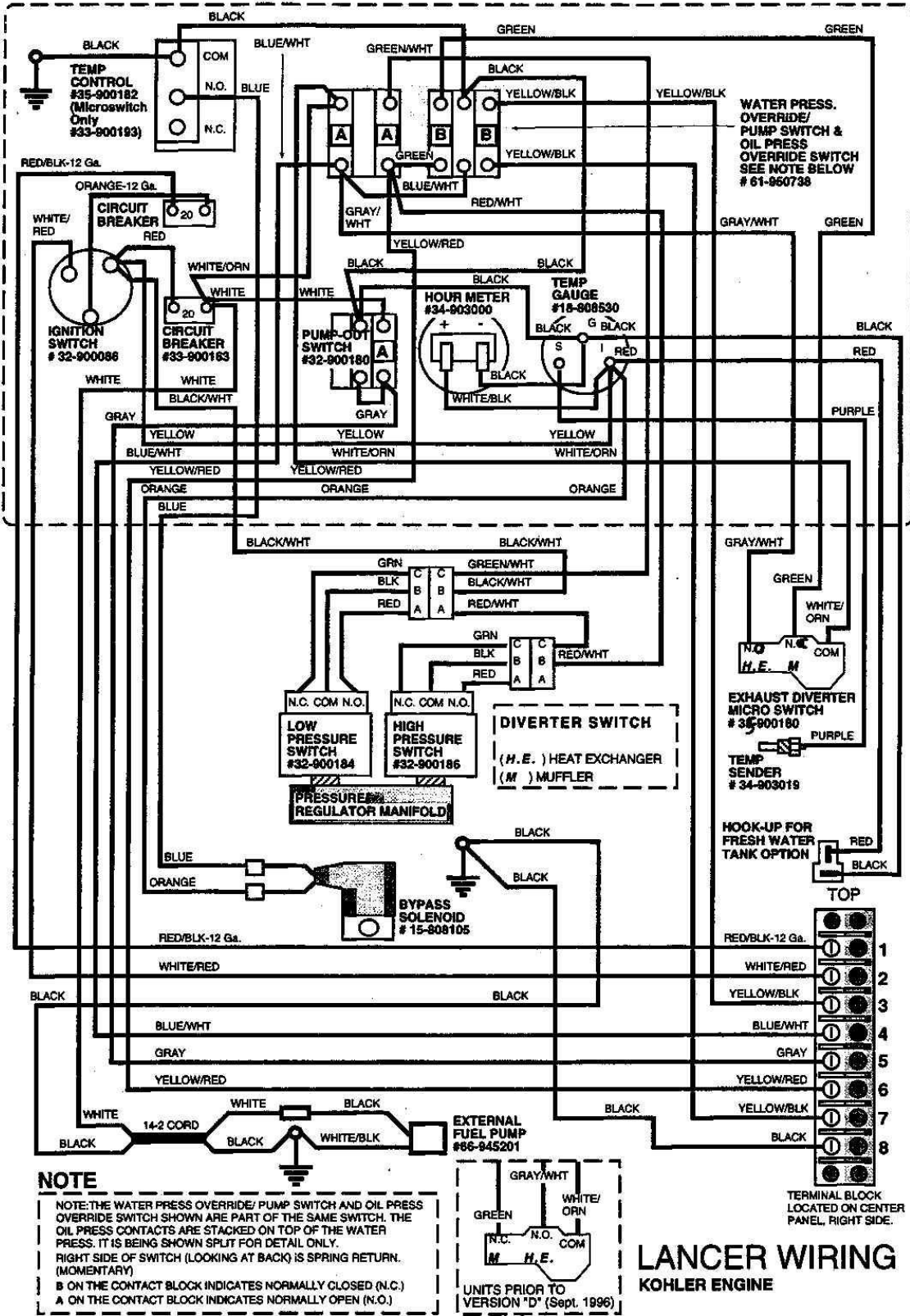

NOTE
 NOTE: THE WATER PRESS. OVERRIDE/ PUMP SWITCH AND OIL PRESS. OVERRIDE SWITCH SHOWN ARE PART OF THE SAME SWITCH. THE OIL PRESS. CONTACTS ARE STACKED ON TOP OF THE WATER PRESS. IT IS BEING SHOWN SPLIT FOR DETAIL ONLY.
 RIGHT SIDE OF SWITCH (LOOKING AT BACK) IS SPRING RETURN. (MOMENTARY)
 B ON THE CONTACT BLOCK INDICATES NORMALLY CLOSED (N.C.)
 A ON THE CONTACT BLOCK INDICATES NORMALLY OPEN (N.O.)

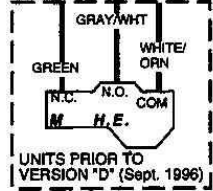

LANCER WIRING
KOHLER ENGINE

Illustrated Parts Listings

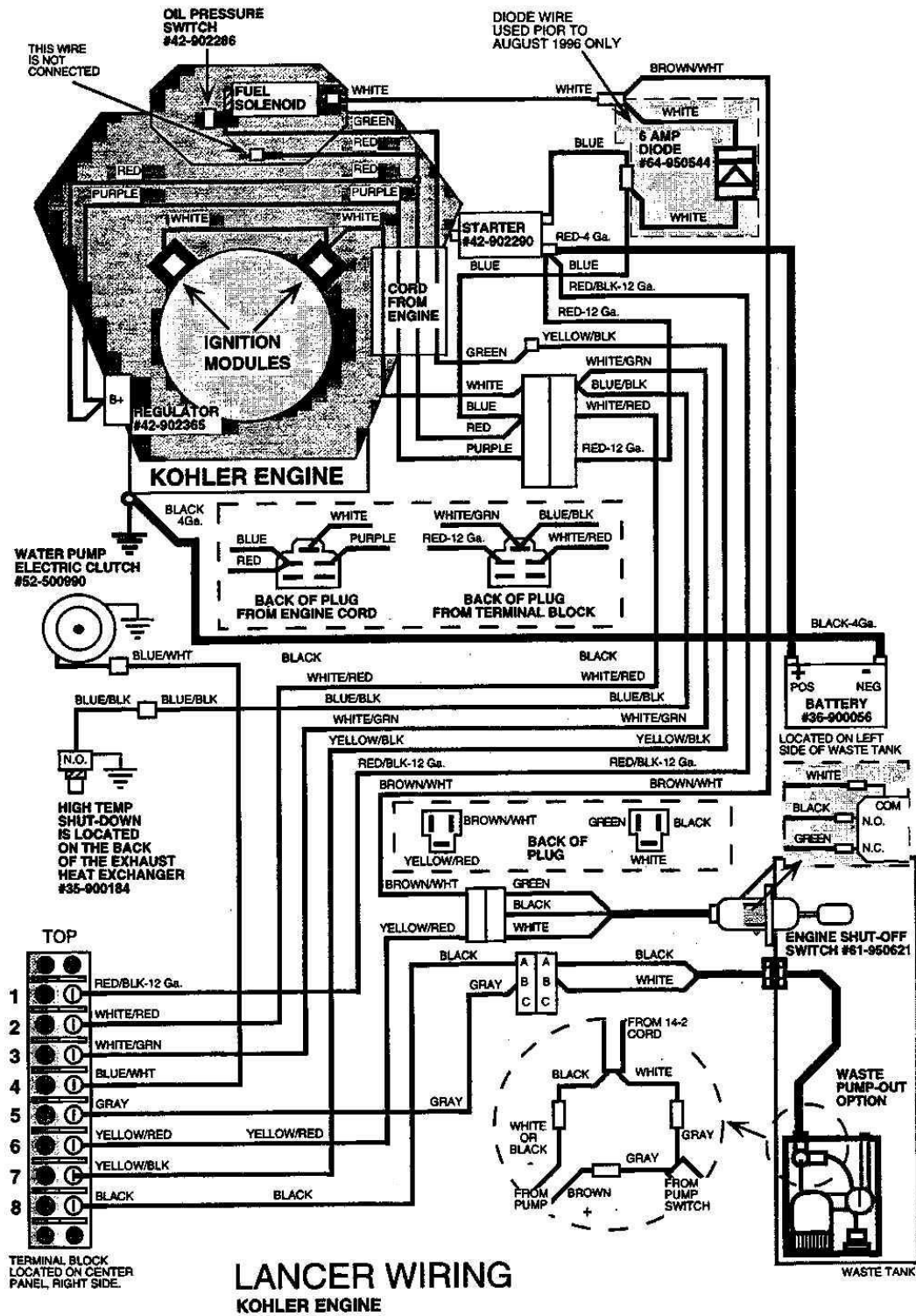

MAINTENANCE CHART

daily maintenance	Engine	daily	Check engine oil level.*** Fill to proper level.
	Vacuum Pump	daily	Spray WD-40 in lubrication cup at front of console
	Water Pump	daily	Check oil level.** Fill to proper level.
	Vacuum Inlet Filter (in waste tank)	daily*	Clean filter, inspect, replace if damaged.
	Vacuum Hoses	daily	Wash out with clean water
	(Optional) Automatic Waste pump	daily*	Inspect and remove any debris or sediment

Vacuum Pump	weekly*	Check oil level. Fill to proper level.
Engine	weekly	Examine air intake and cooling areas. Clean, if required
Engine	weekly	Check air cleaner for dirty, damaged, or loose parts.
Water Pump Inlet Filter (in water box)	weekly*	Check for debris and clean
Battery	weekly*	Check for proper fluid level. Fill with distilled water only .
Bypass Manifold Orifice & Strainer	weekly*	Inspect & remove any debris or blockage
Solution Outlet Y-Strainer	monthly*	Inspect & remove any debris or blockage
High Pressure Hoses	25*	Inspect for damage or impending damage
Engine	25	Service pre-cleaner element
Pressure Regulator	100	Lubricate O-rings
Engine	100	Change engine oil***
Engine	100*	Service air cleaner element*
Battery	100*	Clean battery terminals
Engine	100	Remove cooling shrouds and clean cooling areas
Engine	100	Check condition & re-set gap on spark plugs
Heat Bypass and Chemical Valves	200*	Inspect and/or Adjust Packing Nuts
Temperature Solenoid	200*	Remove any hard water deposits
Engine	200	Change oil filter***
Water Pump	500	Change oil**
Vacuum Pump	500	Lubricate bearing on pulley end with grease
Sheave Set Screws & Bushing Cap Screws	500	Check for proper torque values. Re-torque, if required****
Drive Sheaves	500	Inspect, clean and check for sheave groove wear****
Drive Sheaves	500	Check sheave alignment****
Drive Belts	500	Inspect and clean****
Drive Belts	500	Check belt tension****
Chemical Pump and Check Valves	1000	Replace Diaphragm and Check valves.
Check Valve (Solution Outlet)	1000	Inspect, Clean and Repair, if needed.
Vacuum Pump	yearly	Drain, flush, and replace oil*****
Nitrogen Accumulator	yearly*	Check and have re-charged with nitrogen, if required

* Or as often as required.

** Change water pump crankcase oil after the first 50 hours of operation.

*** Change engine crankcase oil and filter after the first 5 hours of operation.

**** Perform drive belt, sheave, & bushing maintenance after first 25 hours of operation, and then again at 100 hours.

***** If using AEON PD synthetic lubricant, 4500 hours or every 2 years, whichever comes first.

6 MAINTENANCE

This chapter of the operator's manual contains the maintenance information for this unit.

Initiation of a planned PREVENTATIVE MAINTENANCE PROGRAM will assure that your **Bridgepoint LANCER** has optimum performance, a long operating life, and a minimal amount of "down" time.

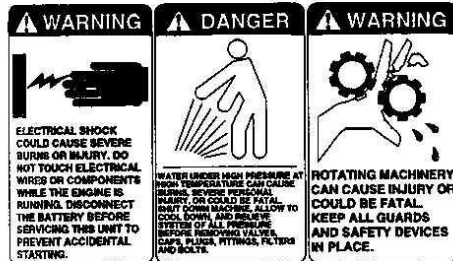

⚠ WARNING:

DO NOT service this unit while it is running. The high-speed mechanical parts as well as high temperature components may result in severe injury, severed limbs, or fatality.

NOTE: Use the hour meter as a guide for coordinating the maintenance schedule.

1. ENGINE:

Major engine repairs should **NOT** be attempted without a thorough knowledge of all components of the engine. Therefore, we strongly **RECOMMEND** having service or repairs performed by an authorized engine dealer.

General maintenance, filter changes, oil change, etc., should be performed as recommended by the **Kohler Engine Operation and Maintenance Manual**. Use the engine manual as a detailed guide for **ALL** matters concerning the engine. Following is a condensed version of maintenance procedures:

1. Check the engine oil level **daily**, when in use.

We recommend using the following chart

Use high-quality detergent oil of **API (American Petroleum Institute) service class SF or SG**. Select the viscosity based on the air temperature at the time of operation as shown in the following table:

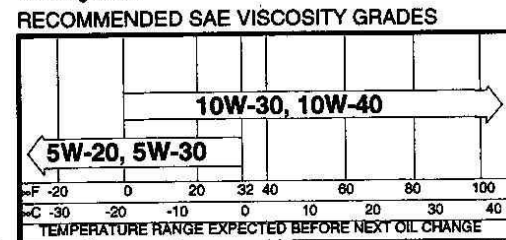

NOTE: Using other than service class SF or SG oil or extending oil change intervals longer than recommended can cause engine damage.

2. It is important that the engine break-in oil is changed after the **first five (5) hours** of operation. Afterwards, change the engine oil **every 100 hours**.
3. Examine air intake and cooling areas **weekly**. Clean if required.
4. Check the air cleaner **weekly** for dirty, damaged, or loose parts.
5. Service the precleaner element **every 25 hours**.
6. Service the air cleaner element **every 100 hours**.
7. Check condition of the spark plugs and gap **every 100 hours**.
8. Remove the cooling shrouds and clean the cooling areas **every 100 hours**.
9. Change the oil filter **every 200 hours**.

NOTE: Perform these maintenance operations more frequently under extremely dirty or dusty conditions.

2. VACUUM PUMP:

Refer to **Vacuum Pump Operation and Service Manual** for specific instructions.

Lubrication: We recommend that you use AEON PD Synthetic Blower Lubricant in the gear end of the vacuum pump for ALL operating temperatures. AEON PD is formulated especially for positive displacement blower service to provide maximum blower protection at any temperature. One filling of AEON PD will last a minimum of 2 times longer than a premium mineral oil.

AEON PD (Part# 05-008039) is the oil which Bridgepoint puts in the vacuum pump at the factory. Topping off or adding petroleum oil to synthetic oil is NOT recommended.

If not using AEON PD synthetic blower lubricant, use oils with rust and oxidation inhibitors, anti-foam additives and the viscosity's listed on the chart on this page.

VACUUM PUMP LUBRICANT

1. Check the oil level **weekly** to assure the proper level. **PROPER LEVEL** cannot be overemphasized. Too little oil will ruin bearings and gears. Too much oil will cause overheating. Use the chart provided on this page as a guide when adding oil.

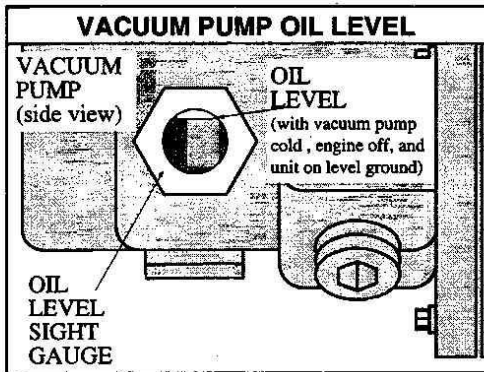

2. To prevent rust from building up inside the vacuum pump (if moisture exists) we have provided a lubrication cup on the front of the unit.

First run the unit at least 1 minute to remove any moisture from the vacuum pump.

Next, fill the lubrication cup with WD-40 or a similar lubricant while the unit is running and the vacuum inlet is sealed. Do this at the end of **each working day**.

3. Drain, flush and replace oil **every 1500 hours or yearly, whichever comes first**. Change oil more frequently if inspection so indicates. With AEON PD synthetic lubricant, perform the oil change maintenance **every 4500 hours or every 2 years, whichever comes first**.

VACUUM PUMP LUBRICANT

Blower Discharge Temperature	Oil Grade U.S.A.*	Oil viscosity, Centistokes @ 40° C
-40° to 32°F (-40° to 0°C)	SAE 10W	45
32° to 100°F (0° to 38°C)	SAE 20	100
100° to 275°F (38° to 135°C)	SAE 40	200
over 275°F (135° C)	SAE 50	250

* In applications with extreme variations in ambient temperature a 20W-50W multiple viscosity is recommended.

For Grease Lubricated Bearings	
Service every 500 hours of operation	
Blower Discharge Temperature	Type Grease
-40° to 275°F (-40° to 120° C)	No. 2 Non-Corrosive Bearing Grease

4. The bearings on the pulley end of the vacuum pump requires grease lubrication **every 500 hours**. Pack the bearings until grease comes out of the vent holes. (Use extreme pressure bearing grease of the specification NLGI Grade 2 EP)

3. WATER PUMP:

Refer to the **Water Pump Operation and Service Manual** for specific instructions.

1. Check the crankcase oil level **daily** to assure the proper level. If the level has dropped, check for the source of leakage and repair.

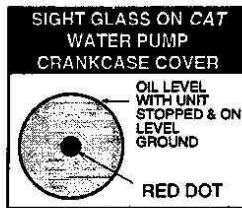

Refill the oil to the proper level, if required, with Cat Pump Oil (Part# 05-008016), SPECIAL FORMULA PREMIUM 10W30 GRADE NON-DETERGENT HYDRAULIC Oil. Other CAT approved oil equivalents are:

Mobil DTE 16
Amoco Rykow 68
Shell Tellus T68

2. Change the crankcase oil with Cat Pump Oil after the first 50 hours of operation. Drain and refill the crankcase oil every 500 hours thereafter.

4. VACUUM INLET FILTER (in waste tank):

The vacuum filter in the waste tank should be removed and cleaned **daily**. Re-install the filter *hand-tight*. If this is done, the filter will last for a long period of time.



CAUTION:

When removing the vacuum inlet filter, grip the plastic hexagonal section of filter. Grasping filter by the screen may collapse or ruin the filter. NEVER operate this unit with this filter removed, damaged or improperly installed.

Replace this filter if damaged or as needed.

NOTE:

When replacing this filter, we recommend using a stainless steel filter (#14-806518) **only**. This will prevent rust and corrosion from entering the vacuum system.

5. DRIVE BELTS, SHEAVES, & BUSHINGS:

1. Check sheave set screws and/or bushing (hub) cap screws after the first 25 hours and then again at 100 hours.

Re-torque these screws with a torque wrench, using the values on the chart below.

Check sheave set screws and/or bushing (hub) cap screws every 500 hours thereafter.



WARNING:

Make certain that when you re-torque these screws, that you use a clockwise pattern and continue until proper torque is achieved.

TORQUE VALUES

Component	inch/lbs	foot/lbs
Engine hub	264	22
Vacuum pump hub	192	16

2. Check for sheave groove wear, clean belts and sheave grooves, check for worn belts, proper belt tension, and sheave alignment after the first 25 hours and then again at 100 hours.

Check for belt ride in the groove. In multiple groove drives, belt ride should be uniform, not more than 1/16" above or below top of sheave groove.

Check groove wear area for wear. Side wall of groove should be straight, not dished out. Bottom of groove should show no signs of belt contact.

Inspect belts for contaminates, such as oil or grease. Wipe belts clean with detergent and water. Inspect sheave grooves for buildup of such material and remove, if necessary.

Check wear surfaces of belt for excessive wear. If have a slick, glazed look, belts are slipping. Check belt tension. Never replace one belt in a used set, as used belts will elongate. Replace entire set if replacement is necessary.

Place a straight-edge across the top of belt. There should be no more than 1/2" deflection in the center of the belt, halfway between the sheaves. If there is too much slack, tighten belt, making sure that it stays properly aligned.

See "General Service Adjustments Section" in this manual for details.

Check alignment with straight-edge, string, or machinist level. Correct alignment to as near perfect as possible.

6. FLOAT VALVE (water box):

Check the float valve at least once a month for proper operation. If overfilling is a problem, check the plunger for a proper seat. Replace tip on plunger if needed or damaged. Water level in the water box should be about 6-1/2".

For procedure, see "General Service Adjustments Section" in this manual for details.

7. INLET FILTER (to water pump):

The filter inside the water box on the bottom is rubber with a stainless steel screen. This should be inspected and cleaned on a weekly basis, if damaged, replace.

NOTE: Vacuum all excess water and debris from water box prior to removing strainer.

8. WASTE TANK STRAINER BASKET

The strainer basket located inside the waste tank should be removed and cleaned whenever it is full of debris. This should be done on at least a **daily** basis.

9. BYPASS MANIFOLD (strainer and jet block):

Check the strainer and the jet weekly. Remove any debris or blockage.

For procedure, see "General Service Adjustments Section" in this manual for details.

10. Y-STRAINER (outlet):

Inspect the Y-strainer after the first week of running the unit by unscrewing the screen and remove any accumulated debris.

Inspect the strainer again at **2 and 4 weeks**.

The Y-strainer should then be inspected **every month**. However, if the Y-strainer has a frequent build-up of debris it should be inspected and cleaned more often.

11. CHECK VALVE (outlet):

Inspect the check valve when rebuilding the chemical pump or as needed. Remove and disassemble the check valve. Check the Teflon seat for debris or abnormal wear. Clean or replace seat if needed.

NOTE: Improper seating of the check valve poppet, damaged spring or o-rings will cause poor operation of the chemical system.

For procedure, see "General Service Adjustments Section" in this manual for details.

12. CHEMICAL PUMP:

Rebuild the chemical pump **every 1000 hours**. This involves changing the diaphragm and check valves.

For procedure, see "General Service Adjustments Section" in this manual for details.

13. CHEMICAL & HEAT BYPASS VALVES:

Examine the packing nut on the chemical selector valve, heat bypass valve, and chemical metering valve **every 200 hours**. Keeping these valve packings properly adjusted will eliminate possible leakage from the valve stems and add to overall valve life.

For procedure, see "General Service Adjustments Section" in this manual for details.

14. NITROGEN ACCUMULATOR:

Check the nitrogen pre-charge at **least once a year**. Recharge the accumulator and replace the bladder, when needed. This should be performed by an *Authorized Service Center*.

**WARNING:**

Recharge accumulator with nitrogen ONLY. DO NOT charge accumulator over 250 PSI.

15. PRESSURE REGULATOR:

Lubricate the o-rings **every 100 hours**. Use lubricant #05-008035.

For procedure, see "General Service Adjustments Section" in this manual for details.

16. VACUUM HOSES:

To assure maximum hose life, we recommend that the hoses be washed out with clean water at the end of **each working day**.

17. CATALYTIC AIR PUMP:

Check and/or replace the air pump every 1500 hours. When replacing, it will also be necessary to replace the air pump pulley.

18. TEMPERATURE SOLENOID:

Remove hard water deposits from the temperature solenoid every 200 hours or as often as required.

For procedure, see "General Service Adjustments Section" in this manual for details.

19. BATTERY:**WARNING:**

Dangerous Acid, Explosive Gases!

Batteries contain sulfuric acid. To prevent acid burns, avoid contact with skin, eyes and clothing. Batteries produce explosive hydrogen gas while being charged. To prevent a fire or explosion, charge batteries only in well ventilated areas. Keep sparks, open flames, and other sources of ignitions away from the battery at all times. Keep batteries out of the reach of children. Remove all jewelry when servicing batteries. Before disconnecting the negative (-) ground cable, make sure all switches are OFF. If ON, a spark will occur at the ground cable terminal which could cause an explosion if hydrogen gas or gasoline vapors are present. When disconnecting the battery, ALWAYS disconnect the negative (-) terminal FIRST.

1. Check the fluid level in the battery every 25 hours or once a week. If low, fill to the recommended level with distilled water ONLY.

**NOTE:**

DO NOT overfill the battery. Poor performance or early failure due to loss of electrolyte will result.

2. Keep the cables, terminals, and external surfaces of the battery clean. A buildup of corrosive acid or grime on the external surfaces can cause the battery to self-discharge. Self discharge occurs rapidly when moisture is present.

The battery terminals should be cleaned every 100 hours to prevent corrosion build-up. Wash the cables, terminals and external surfaces with a mild baking soda and water solution. Rinse thoroughly with clear water.

**WARNING:**

DO NOT allow the baking soda to enter the battery cells as this will destroy the electrolyte.

20. ENGINE EXHAUST HEAT EXCHANGER:

If the engine and/or air pump are not properly maintained, the exhaust gases may deposit carbon on the outside of the heat exchanger coil and continuous running will effect the cleaning solution temperature and may cause damage to the catalytic converter. If this condition exists, remove the heat exchanger from the unit and clean the carbon off the coil. This may be done by taking it to a machine shop and having it boiled out. **The catalytic converter must be completely removed before cleaning carbon deposits or damage may result.**

Proper maintenance of the unit, such as regular tune-ups, proper fuel and a properly operating air pump will help prevent carbon build-up on the coil and increase the life of the unit.

In case of carbon build-up using **Bridgepoint Industrial** cleaner will greatly enhance the removal of carbon deposits. Soak the coil and casing only. **(NEVER soak the catalytic converter core).** This should be performed as needed.

21. VACUUM EXHAUST HEAT EXCHANGER:

Removing and cleaning the vacuum exhaust pre-heater core is recommended as needed or if the unit was operated with the vacuum inlet filter damaged, removed or improperly installed. Pull out the core and remove all debris, being **careful not to drive debris deeper into the core.** Remove the debris with water by either submerging the core and moving it back and forth until the debris loosens and falls off or by spraying the debris out of the core. Allow the core to dry before reinstalling.

22. HIGH PRESSURE HOSES:

Inspect your high pressure hoses for wear after the **first 100 hours** of use. Inspect **every 25 hours thereafter**. If hoses show any signs of damage or impending rupture, **replace the hose**.

**CAUTION:**

DO NOT attempt to repair high pressure hoses! Repairing high pressure hoses may result in severe burns and serious injury!

All high pressure hoses must be rated for 3000 PSI at 250°F. Thermoplastic hoses do not meet these specifications and should not be used. Severe burns and injury may result if the hoses do not meet these requirements.

23. OPTIONAL WASTE PUMP-OUT:

At the end of each work day, make certain that you remove any debris or sediment which may be inside the waste pump.

Remove waste pump unit from waste tank and clean inside underneath screen at least **once a week**, or more frequently if required.

24. TEMPERATURE UNION PACKING:

Examine the temperature union assembly for leaks **every 200 hours**. Tighten the union fitting just enough to stop leaks. **DO NOT** over tighten.

For procedure, see "General Service Adjustments Section" in this manual for details.

7 SERVICE GENERAL ADJUSTMENTS



WARNING:

DO NOT service this unit while it is running. The high-speed mechanical parts as well as high temperature components may result in severe injury, severed limbs, or fatality.

1. ENGINE SPEED:

To adjust the engine RPM, refer to the **Kohler Engine Operation and Service Manual** for specific instructions.



WARNING:

DO NOT attempt to adjust without a tachometer and **NEVER** adjust the engine above 2800 RPM.

2. VACUUM RELIEF VALVE:

While the unit is running at full RPM, block the air flow at the vacuum inlet connection and read the vacuum gauge. If adjustment is required, shut the unit down and adjust the locking nut tension. Start your unit and read the vacuum gauge. Repeat this process until the relief valve opens at 14" Hg.

3. VACUUM PUMP DRIVE BELTS:

To tighten the vacuum pump belts:

1. Loosen the 2 nuts which hold the air pump mount in place.
2. Loosen the 4 locking-nuts which hold the vacuum pump mount in place.
3. Turn the adjusting bolts until the proper belt tension is achieved (1/2" deflection in the center of the belt) halfway between the sheaves.

CAUTION: When adjusting belt tension, make certain that the engine shaft and vacuum pump shaft remain parallel, and the belt tension is equal throughout the belt width.

4. After adjusting, re-tighten the 4 nuts which hold the vacuum pump in position. Check belt alignment with straight edge.

5. Readjust and check air pump belt. **DO NOT** over tighten belt. Re-tighten the 2 mounting nuts. Check alignment with straight edge.

4. WATER PUMP DRIVE BELT:

To tighten the water pump belt:

1. Loosen the nuts which hold the water pump mount to base.
2. Adjust the belt tension adjusting bolt until the proper belt tension is achieved. (1/2" deflection in the center of the belt halfway between the sheaves).
3. While checking the alignment, tighten the pump mount hold-down nuts.

5. FLOAT VALVE (water box):

The float valve should only be adjusted if the water box is overflowing or the water level in the box is lower than 5-1/2":

1. If the box is overflowing, remove, and check the float valve for debris or damage.

NOTE: If the float ball has any water inside it must be replaced.



CAUTION:

When replacing float ball, DO NOT over tighten, the rod can puncture ball. Make sure to tighten nuts on rod.

2. Disassemble the valve and check the piston and seat for damage, replace if needed. See page A-11 for break-down.

3. Reassemble and reinstall valve, adjust shut-off by bending the rod slightly either up or down. Down will shut the valve sooner (lower water level).

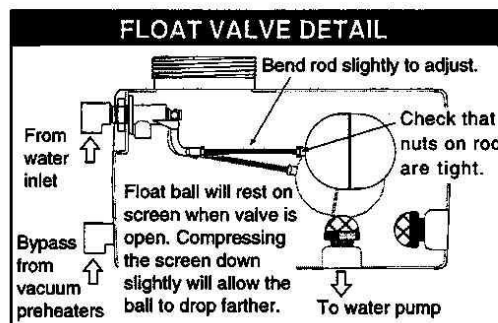

6. BYPASS MANIFOLD:

Clean the bypass strainer and orifice weekly, using the following guidelines:

1. Remove the **strainer**. Clean and re-install. **DO NOT** over tighten strainer.
2. Remove the **cap**. Remove the **orifice**, using a 3/16" Allen wrench. (The 3/16" Allen wrench is provided with the bypass maintenance kit #66-945280.)
3. Re-install the **cap** and run the unit with the water pump ON for 15 seconds to flush out the bypass block.
4. Remove the **cap** and re-install the cleaned **orifice**, using the 3/16" Allen wrench. Tighten **orifice** just enough to seat. **DO NOT** over tighten. Re-install **cap**. **DO NOT** over tighten **cap**.

NOTE: If o-ring seals leak, replace them. If strainer is damaged, replace strainer.

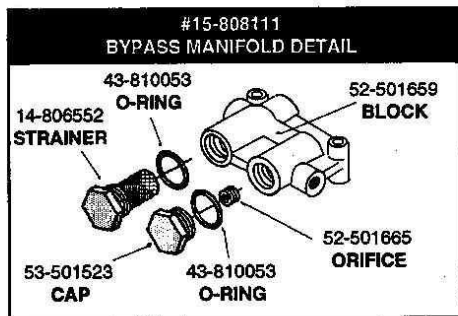
**7. CHECK VALVE (solution outlet):**

Inspect the check valve whenever doing service on the chemical pump or if flow problems occur in the chemical system:

1. Remove the **check valve**. Be sure the small o-ring for the seat comes out with the check valve.
2. Remove the **seat**, using a 5/16" Allen wrench.
3. Check the Teflon seat for debris or wear. Clean or replace Teflon seat if needed.
4. Clean the **poppet** and **spring**, inspect for wear or damage, replace as needed.

5. Re-assemble the check valve. Start the seat by hand, tighten using a 5/16" Allen wrench. **DO NOT** over-tighten seat.

NOTE: Improper seating of the check valve poppet, damaged spring or o-rings will cause poor operation of the chemical system.

6. Lubricate the o-rings with **lubricant #05-008035** and reinstall.

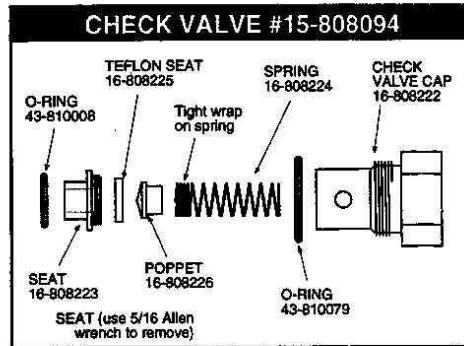
**8. CHEMICAL PUMP:**

The only repairs which the chemical pump may require is the replacement of the diaphragm or check valves. To replace the diaphragm, unscrew the cover from the body. When replacing the diaphragm, lubricate the outer edges of the diaphragm with **lubricant #05-008035** and reassemble. To replace the check valves, unscrew the check valve caps. Replace the check valves and reassemble, using new o-rings and Teflon washers

NOTE: Teflon washers were used on units prior to July 1, 1996.

DO NOT attempt to re-use the Teflon washers once the check valves have been removed.

See page A-7 in the Illustrated Parts Listing for a parts breakdown on the chemical pump.

9. PACKING NUT ADJUSTMENT for CHEMICAL METERING, CHEMICAL SELECTOR, & HEAT BYPASS VALVES:

Examine the packing nut on the metering and selector valves for proper tension every **200 Hours**. When turning the knob, there should be a small amount of resistance. If not, slightly

tighten the packing nut. **DO NOT** over tighten. Keeping the valve packings properly adjusted will eliminate possible leakage from the valve stem and add to overall valve life.

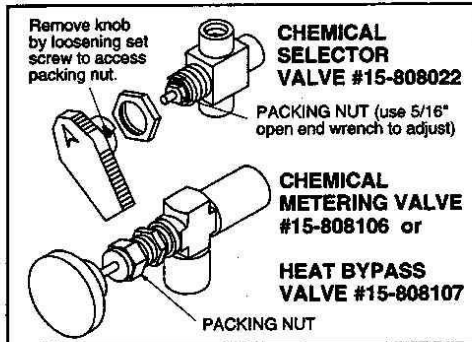

10. PRESSURE REGULATOR:

The pressure regulator serves only to hold locked up water pressure at a preset point and to bypass this water back to the water box. Adjust as follows:

To adjust:

1. With your unit running, close the cleaning tool. Check the pressure gauge. Open the tool valve. We **recommend** setting the pressure regulator so that the pressure gauge reads 400 PSI with the tool valve **open**.

When the tool valve is open, there is an approximate drop of 100 PSI in pressure. If there is a pressure drop greater than 100 PSI, it may be necessary to lubricate the o-rings in the pressure regulator.

2. If the pressure regulator requires adjustment, turn the adjusting knob (while observing the pressure gauge on the control panel) until the desired pressure is obtained.

#15-808068 PRESSURE REGULATOR

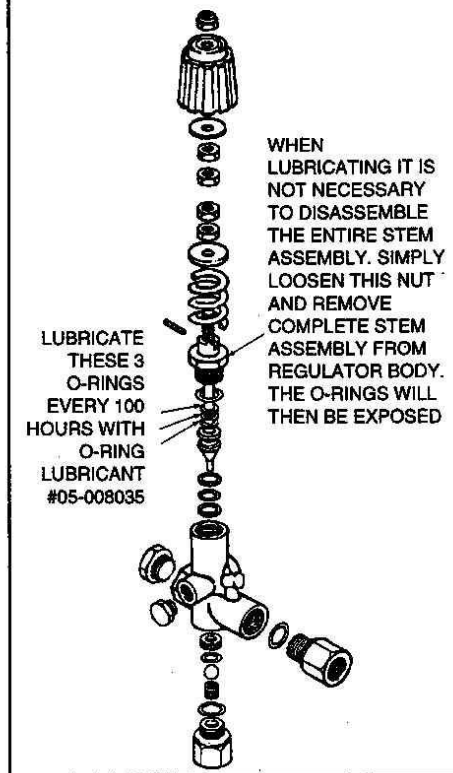

11. TEMPERATURE SOLENOID:

The temperature solenoid may become seized, due to hard water deposits.

The core must move freely in the stem. The plunger must move freely within the guide.

Check the seat to make sure that it is not distorted.

Using the illustration on the following page, follow these guidelines when servicing the temperature solenoid:

1. Remove the coil housing from the solenoid body.
2. Using the spanner wrench, remove the stem, spring core, plunger, guide, and seal washer. NOTE: DO NOT attempt to remove seat. (The

spanner wrench is provided with the bypass maintenance kit #66-945280.)

3. Make certain that the **plunger** moves freely in the **core** and the **guide**. The **core** must also move freely in the **stem**.

These parts may be soaked in de-scaler or cleaned with #0000 steel wool.

4. Clean **seat** by gently rotating a 3/64" drill bit with fingers through the center of the seat. (The 3/64" drill bit is provided with the bypass maintenance kit #66-945280.)

5. Reassemble the **solenoid**. **DO NOT** over tighten **stem** or **coil mounting nut**. Doing so may cause damage to the solenoid or improper operation.

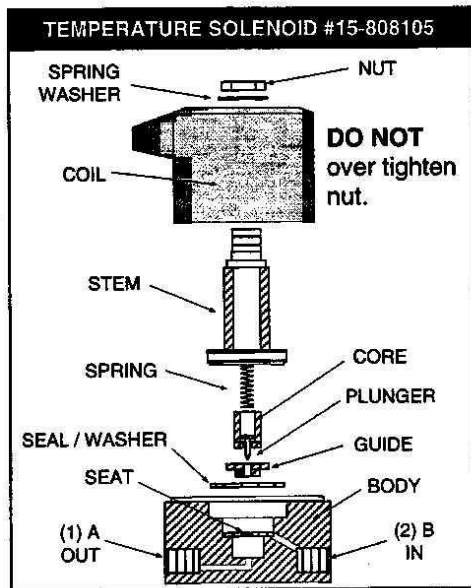
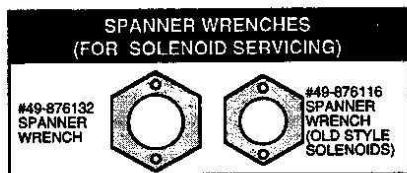

12. TEMPERATURE CAPILLARY & PACKING ASSEMBLY:

INSTALLATION INSTRUCTIONS for OLD STYLE UNION #12-800130

1. Using thread sealant, thread the tapered end of the union into the thermostat manifold and tighten.

2. Slide the jam nut over the capillary bulb with the threaded end towards the bulb.

3. Insert bulb through union fitting into the thermostat manifold.

4. Slide the compression slugs on to the capillary with the concave surfaces facing each other. (see illustrations on this page and the following page.)

5. Fit the (2) silicone discs and (4) sealing discs on to the capillary between the slugs in the order shown in the illustration. Align slits 180° apart.

6. Insert slugs and discs into the union fitting hand tight.

7. Position bulb in manifold as shown in the illustration on the following page. When positioning the bulb in the support fitting, do not allow bulb to compress against the support fitting.

8. Tighten jam nut lightly approximately 1-1/2 turns.

9. Examine the union assembly for leaks and tighten union fitting just enough to stop leaks. **DO NOT OVER TIGHTEN.**

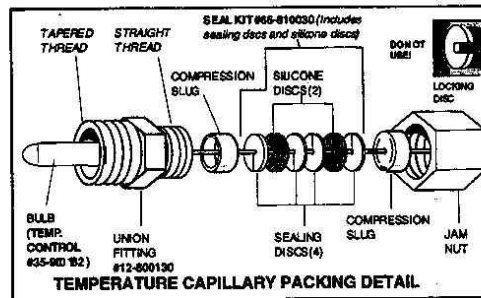

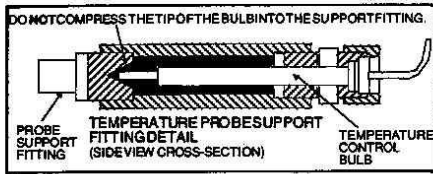

INSTALLATION INSTRUCTIONS for NEW STYLE UNION #12-800391

1. Using thread sealant, thread the tapered end of the union into the thermostat manifold and tighten.
2. Slide the jam nut over the capillary bulb with the threaded end towards the bulb.
3. Insert bulb through union fitting into the thermostat manifold.
4. Place the rubber seal on to the capillary with the split facing 90° from top. (*see illustration on this page*)
5. Fit the (4) brass disks on to the capillary on either side of the rubber seal. Face notch on disk towards other disk.

NOTE: Lubricating the facing sides of the brass disks will hold them together on the capillary tube during installation.

6. Insert rubber seal and discs into the capillary union fitting hand tight.
7. Position bulb in manifold as shown in the illustration above. When positioning the bulb in the support fitting, do not allow bulb to compress against the support fitting.
8. Tighten jam nut lightly approximately 1-1/2 turns.
9. Examine the union assembly for leaks and tighten union fitting just enough to stop leaks. **DO NOT OVER TIGHTEN.**

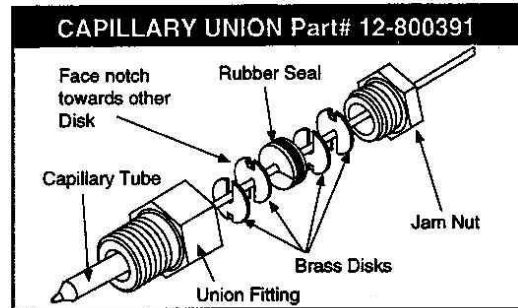

FRONT VIEW ASSEMBLY

NOTE: View is of the "D" version, older versions may differ slightly.

This manual also covers Lancer units manufactured after Sept. 1996. These units will be identified with a letter "D" stamped after the serial number on the plate, located as shown below.

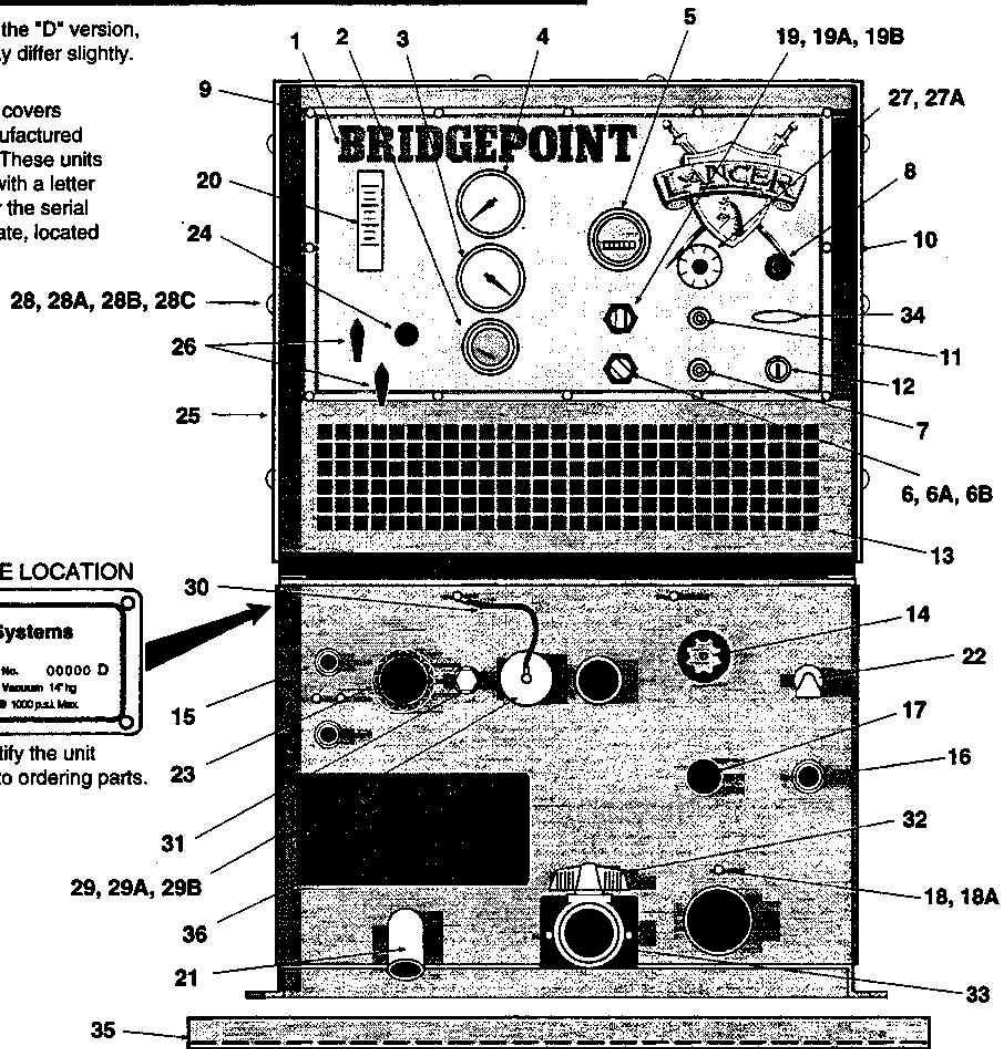

SERIAL PLATE LOCATION

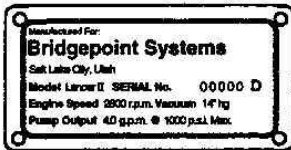

Be sure to identify the unit you have prior to ordering parts.

- | | |
|--|---|
| 1 50-501765.....CONTROL PANEL | 20 18-808513.....FLOWMETER |
| 2 18-808530.....TEMPERATURE GAUGE | 21 55-501672.....EXHAUST DEFLECTOR TUBE |
| 3 18-808525.....VACUUM GAUGE | 22 19-800075.....VACUUM LUBRICATION CUP |
| 4 18-808526.....PRESSURE GAUGE | 23 04-000285.....KNOB, EXH. DIVERTER VALVE |
| 5 34-903000.....HOURMETER | 24 15-808106.....CHEMICAL METERING VALVE |
| 6 32-900180.....SWITCH W/ LIGHT | 25 61-950758.....HOOD ASSEMBLY, LEFT |
| 6A 33-900169.....REPLACEMENT BULB | 26 15-808022.....CHEMICAL PRIMING/SELECTOR VALVE |
| 6B 34-900101.....REPLACEMENT LENS | 27 35-900182.....TEMPERATURE CONTROL |
| 7 33-900163.....CIRCUIT BREAKER, 20 amp | 27A 33-900193.....MICROSWITCH, TEMP. CONTROL |
| 8 49-802518.....CHOKE CABLE | 28 01-000259.....RECEPTACLE, 1/4 TURNFAST |
| 9 00-000071.....SCREW, 10-24 x 1/2" | 28A 00-000272.....STUD, 1/4 TURNFAST |
| 10 61-950757.....HOOD ASSEMBLY, RIGHT | 28B 02-000268.....RETAINER, 1/4 TURNFAST |
| 11 33-900161.....CIRCUIT BREAKER, 30 amp | 28C 58-700023.....VIBRATION PAD |
| 12 32-900174.....IGNITION ON/OFF SWITCH | 29 66-945236.....VACUUM PLUG ASSY (Includes Parts# 29A, 29B & 30) |
| 13 56-501981.....MOUNT, CONTROL PANEL | 29A 52-501679.....PLUG, VACUUM INLET |
| 14 15-808068.....PRESSURE REGULATOR | 29B 43-810081.....O-RING, VACUUM INLET PLUG |
| 15 13-806001.....DISCONNECT, 1/4F | 30 64-950383.....HOLDER, VACUUM INLET PLUG |
| 16 13-806008.....DISCONNECT, 3/8F | 31 11-800168.....PLUG, 1/2P |
| 17 15-808107.....TEMP. BYPASS VALVE | 32 15-808080.....VALVE, WASTE OUTLET |
| 18 00-000210.....SCREW, 1/4-20 x 3/4" | 33 56-501686.....WASTE DUMP TUBE |
| 18A 02-000038.....LOCKWASHER, 1/4 | 34 49-802505.....THROTTLE CABLE |
| 19 61-950738.....SWITCH, PUMP/OIL & WTR OVERRIDE | 35 56-501845.....GALVANIZED DRIP PAN (OPTIONAL) |
| 19A 33-900169.....REPLACEMENT BULB | 36 48-941197.....COND. OPER. INSTRUNCT. DECAL |
| 19B 34-900101.....REPLACEMENT LENS | |

NOT SHOWN 48-941212.....WARNING & INSTRUMENTATION DECAL SHEET
48-941312.....HOOD DECAL

STRUCTURAL FRAMEWORK ASSEMBLY

- 1 56-501902.....TRAY, WATER BOX
- 2 00-000055.....SCREW, 1/4-20 x 3/4 HXHD
- 3 02-000038.....LOCKWASHER, 1/4
- 4 02-000066.....FLATWASHER, 1/4
- 5 00-000122.....SCREW, 1/4-20 x 1-3/4 HXHD
- 6 56-502024.....FRONT HOOD BRACKET
- 7 56-501984.....PANEL, ENGINE INSULATION
- 8 42-902282.....GUARD, ENGINE
- 9 00-000286.....SCREW, 1/4-20 x 2-3/4 HXHD
- 10 56-501981.....MOUNT, CONTROL PANEL
- 11 56-501848.....PANEL, LOWER FRONT
- 11A 56-502111.....PANEL, LOWER FRONT (Version "D")

- 12 00-000210.....SCREW, 1/4-20 x 3/4 SOCHD SST
- 13 56-501840.....BASE
- 13A 56-502110.....BASE (Version "D")
- 14 56-501983.....BELT GUARD
- 15 56-502023.....REAR HOOD BRACKET
- 16 00-000222.....SCREW, 7-16-14 x 1-1/2"
- 17 02-000225.....LOCKWASHER, 7/16
- 18 02-000074.....FLATWASHER, 3/8
- 19 58-700024.....VIBRATION PAD
- 20 56-502050.....HOOD MOUNTING BRACKET
- 21 50-501764.....REAR BELT GUARD
- 22 00-000216.....SCREW, 1/4-20 x 1/2 FLTSOCHD
- 23 01-000037.....NUT, 1/4-20 HXHD
- 24 56-501686.....WASTE DUMP TUBE
- 25 54-501650.....SPACER, BELT GUARD
- 26 00-000345.....SCREW, 1/4-20 x 4" HXHD

This manual also covers Lancer units manufactured after Sept. 1996. These units will be identified with a letter "D" stamped after the serial number on the plate, located as shown below.

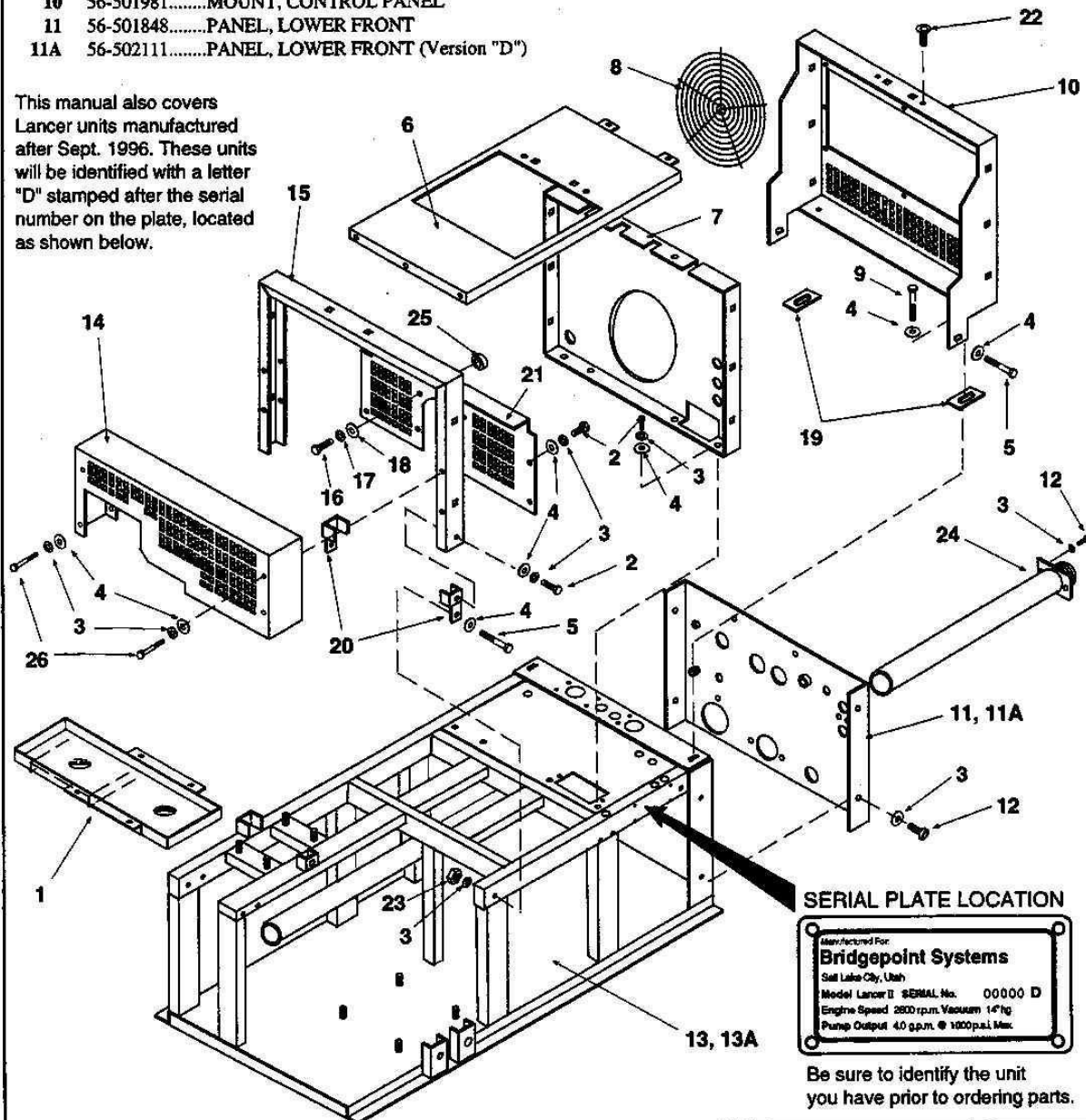

SERIAL PLATE LOCATION

Manufactured For	Bridgepoint Systems
Sal Lake City, Utah	
Model Lancer II SERIAL No.	00000 D
Engine Speed	2800 r.p.m. Vacuum 14" Hg
Pump Output	40 g.p.m. @ 1000 p.s.i. Max.

Be sure to identify the unit you have prior to ordering parts.

ENGINE ASSEMBLY

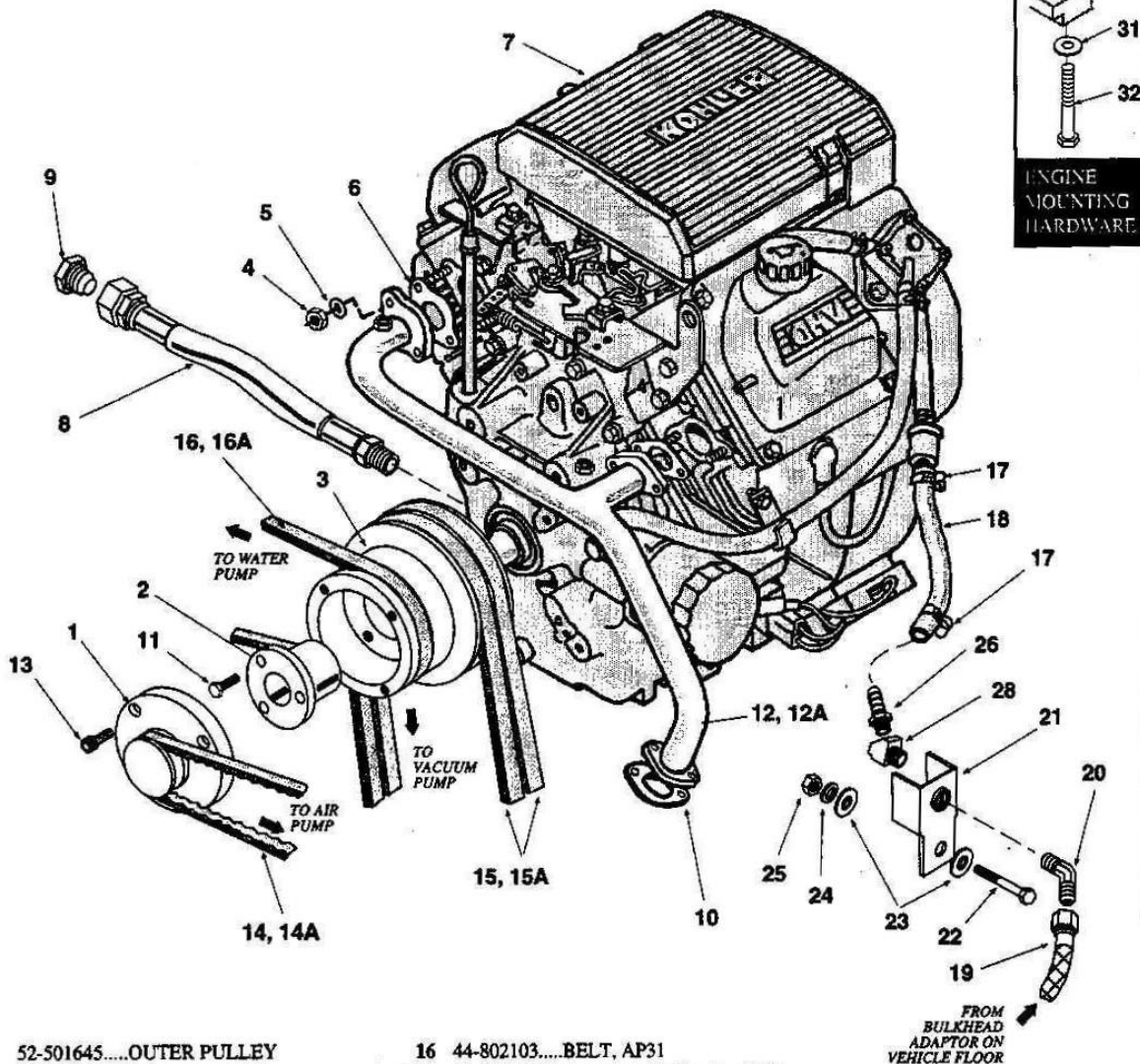

- | | | | |
|-----|--|-----|---|
| 1 | 52-501645.....OUTER PULLEY | 16 | 44-802103.....BELT, AP31 |
| 2 | 44-802182.....HUB, P2 x 1-1/8 | 16A | 44-802236.....BELT, AP32 (Version "D") |
| 3 | 52-501602.....ENGINE PULLEY | 17 | 03-000065.....HOSE CLAMP, #4 |
| 4 | 01-000210.....NUT, 8M-1.25M | 18 | 09-805447.....1/4 FUEL HOSE x 9" |
| 5 | 02-000040.....LOCKWASHER | 19 | 10-805300.....3/16SST HOSE x 45-1/2" |
| 6 | 42-902274.....GASKET | 20 | 12-800261.....45° ELBOW, 1/8P x 1/4T |
| 7 | 40-902122.....KOHLER ENGINE | 21 | 56-501857.....BRACKET, FUEL HOSE |
| 8 | 10-805291.....OIL DRAIN HOSE | 22 | 00-000122.....SCREW, 1/4-20 x 1-3/4" |
| 9 | 12-800062.....DRAIN PLUG | 23 | 02-000066.....FLATWASHER, 1/4 |
| 10 | 42-902212.....GASKET | 24 | 02-000038.....LOCKWASHER, 1/4 |
| 11 | 00-000340.....SCREW, 5/16-18 x 1" | 25 | 01-000037.....NUT, 1/4-20 |
| 12 | 56-501978.....EXHAUST TUBE | 26 | 12-800041.....BARB FITTING, 1/8P x 1/4H |
| 12A | 56-502123.....EXHAUST TUBE (Version "D") | 27 | 03-000242.....HOLD-DOWN CLAMP |
| 13 | 00-000311.....SCREW, PULLEY MT | 28 | 11-800112.....STREET ELL, 1/8P 45° |
| 14 | 44-802210.....BELT, 3VX280 | 29 | 01-000041.....NUT, 5/16-18 HXHD |
| 14A | 44-802233.....BELT, 3VX300 (Version "D") | 30 | 02-000040.....LOCKWASHER, 5/16 |
| 15 | 44-802244.....BELT, AP41 | 31 | 02-000143.....FLATWASHER, 5/16 |
| 15A | 44-802197.....BELT, AP45 (Version "D") | 32 | 00-000247.....SCREW, 5/16-18 x 2" |

KOHLER ENGINE COMPONENT PARTS LIST

- 42-902277.....OIL FILTER
- 42-902286.....OIL PRESSURE SWITCH
- 42-902287.....GASKET, CYLINDER HEAD
- 42-902359.....VALVE COVER KIT
- 42-902360.....VALVE COVER KIT (OIL SIDE)
- 42-902289.....SPARK PLUG
- 42-902290.....STARTER
- 42-902291.....PINION DRIVE
- 42-902292.....SOLENOID
- 42-902293.....CARBURETOR
- 42-902294.....KIT, CARBURETOR REPAIR
- 42-902295.....KIT, HIGH ALTITUDE(9840 FT)
- 42-902296.....FUEL FILTER
- 42-902297.....FUEL PUMP
- 42-902298.....ELEMENT, PRECLEANER
- 42-902299.....ELEMENT, AIR CLEANER
- 42-902365.....VOLTAGE REGULATOR

VACUUM PUMP ASSEMBLY

This manual also covers Lancer units manufactured after Sept. 1996. These units will be identified with a letter "D" stamped after the serial number on the plate, located on the left side as you face unit. Be sure to identify the unit you have prior to ordering parts.

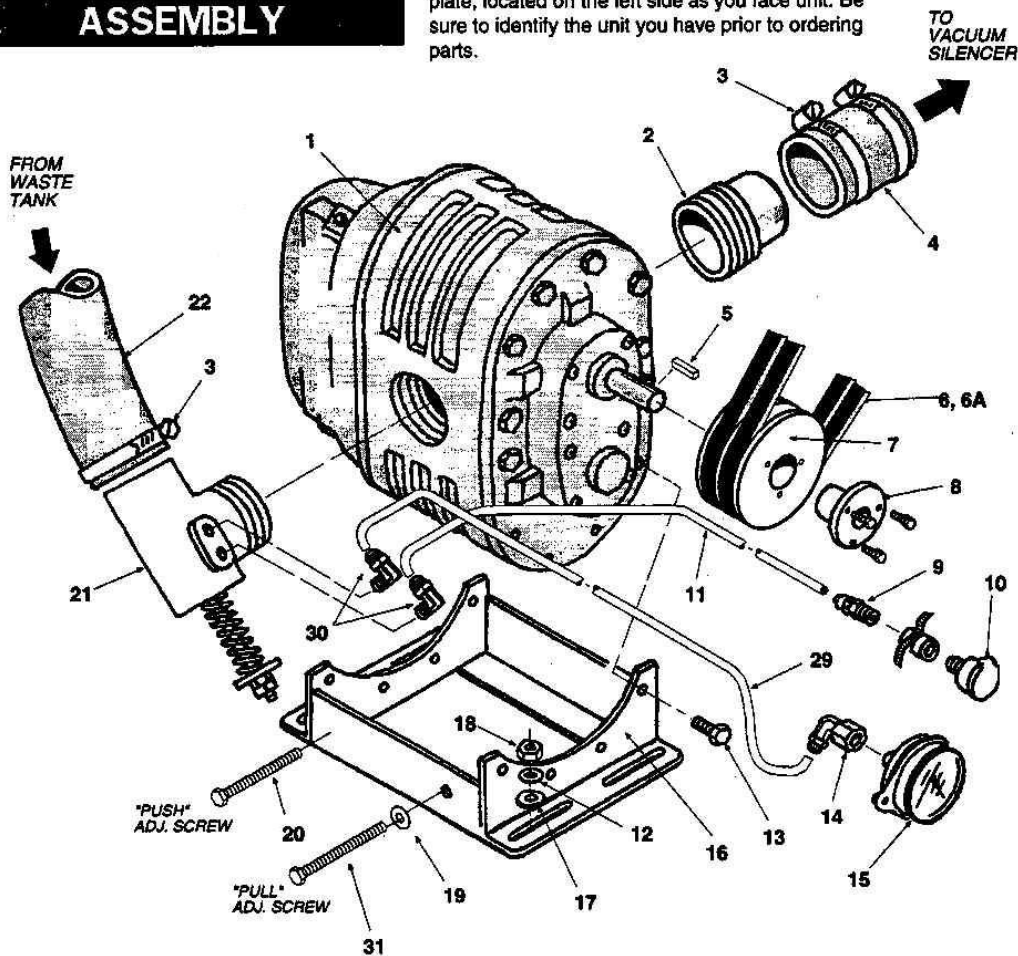

- | | | | |
|----|--|----|--|
| 1 | 41-905021.....VACUUM PUMP | 21 | 61-950698.....RELIEF VALVE ASSEMBLY |
| 2 | 54-501593.....OUTLET NIPPLE | 22 | 09-805341.....HOSE, 2-7/8 x 25" |
| 3 | 03-000112.....HOSE CLAMP #48 | 23 | 56-501615.....STEM, RELIEF VALVE |
| 4 | 09-805401.....HOSE, 2-7/8 x 4" | 24 | 04-000091.....SPRING, RELIEF VALVE |
| 5 | 54-500680.....KEY, SHAFT | 25 | 43-807074.....DIAPHRAGM, RELIEF VALVE |
| 6 | 44-802244.....BELT, AP41 | 26 | 52-501573.....BODY, RELIEF VALVE |
| 6A | 44-802197.....BELT, AP45 (Version "D") | 27 | 02-000269.....FLATWASHER, 7/16 |
| 7 | 44-802212.....PULLEY, VACUUM PUMP | 28 | 01-000224.....NUT, 7/16-14 |
| 8 | 44-802196.....HUB, VACUUM PUMP | 29 | 09-805411.....TUBING, 1/4 x 84-1/2" |
| 9 | 12-800059.....CONNECTOR, 1/8P x 1/4POLYFLO | 30 | 12-800099.....ELBOW, 1/8P x 1/4POLY |
| 10 | 19-800075.....LUBRICATION CUP | 31 | 00-000322.....SCREW, 1/2-13 x 4"(ALL THREAD) |
| 11 | 09-805442.....TUBING, 1/4 x 62-1/2" | | |
| 12 | 02-000075.....LOCKWASHER, 3/8 | | |
| 13 | 00-000095.....SCREW, 3/8-16 X 1" | | |
| 14 | 12-800101.....ELBOW, 1/4FP x 1/4POLYFLO | | |
| 15 | 18-808525.....VACUUM GAUGE | | |
| 16 | 56-501866.....MOUNT, VACUUM ADJUSTING | | |
| 17 | 02-000074.....FLATWASHER, 3/8 | | |
| 18 | 01-000073.....NUT, 3/8-16 | | |
| 19 | 02-000057.....FLATWASHER, 1/2 HEAVY | | |
| 20 | 00-000323.....SCREW, 1/2-13 x 3-1/2" | | |
- NOT SHOWN 05-008039.....OIL, AEON PD (28G24 SUTORBILT)

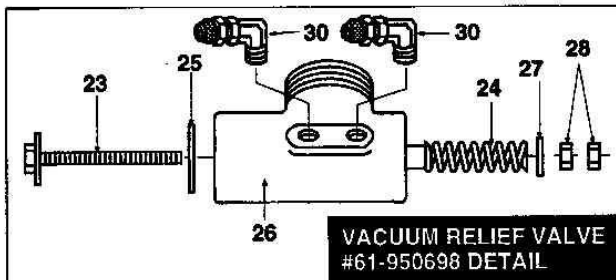

WATER PUMP ASSEMBLY

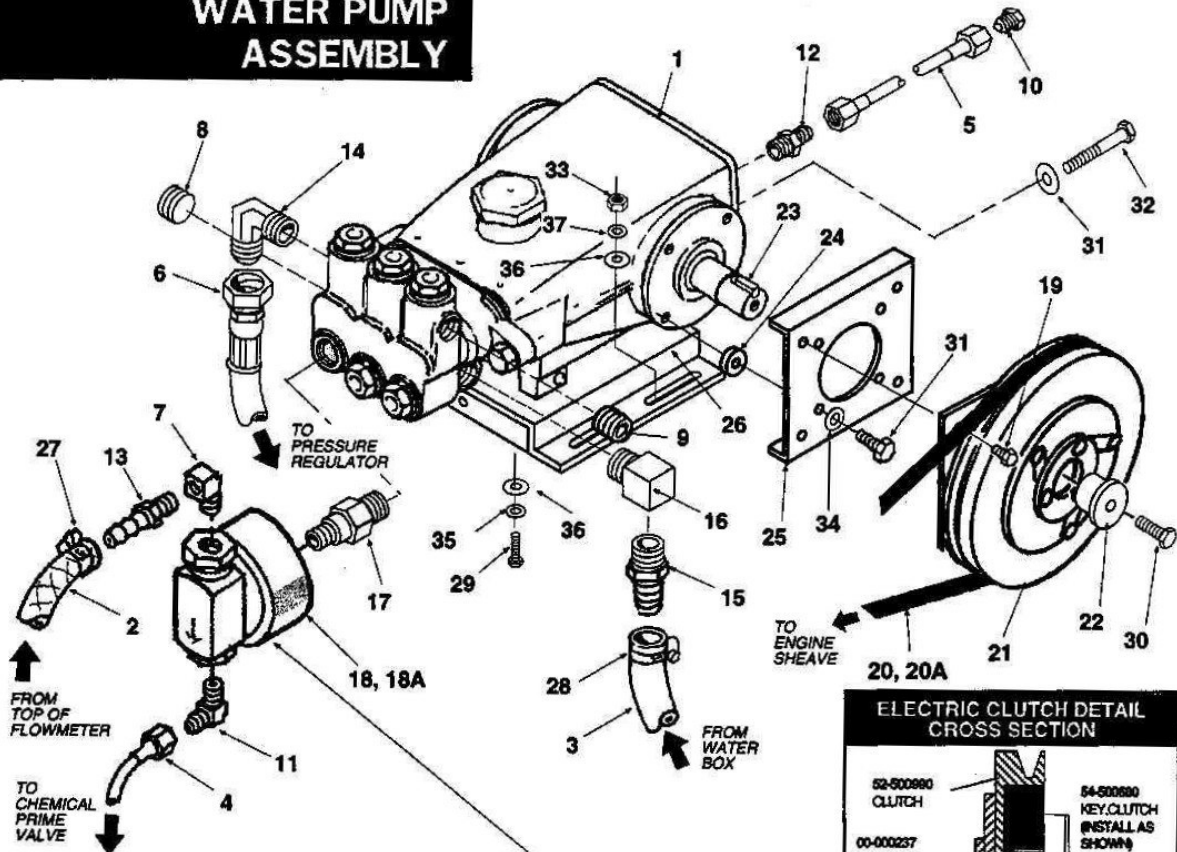

This manual also covers Lancer units manufactured after Sept. 1996. These units will be identified with a letter "D" stamped after the serial number on the plate, located on the left side as you face unit. Be sure to identify the unit you have prior to ordering parts.

**SEE PAGE A-7
FOR CHEMICAL PUMP
BREAKDOWN**

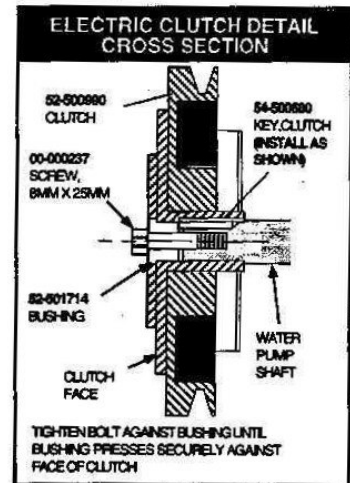

- 1 61-950776.....WATER PUMP
- 2 09-805412.....BRAIDED HOSE, 5/16 x 59"
- 3 09-805435.....HOSE, 3/4 x 33"
- 4 10-805278.....HOSE, 3/16SST x 54"
- 5 10-805316.....HOSE, 3/16SST x 5"
- 6 10-805317.....H. P. HOSE, 3/8 x 37"
- 7 11-800014.....STREET ELBOW, 1/8
- 8 11-800069.....PLUG, 1/2
- 9 11-800224.....PLUG, 3/8
- 10 12-800029.....PLUG, 1/4T
- 11 12-800040.....ELBOW, 1/8P x 1/4T
- 12 12-800060.....CONNECTOR, 1/4P x 1/4T
- 13 12-800093.....BARB FITTING, 1/8P x 5/16H
- 14 12-800225.....ELBOW, 3/8P x 1/2T
- 15 12-800278.....BARB FITTING, 1/2P x 3/4H
- 16 52-800315.....STREET ELBOW, 1/2 (SPECIAL)
- 17 52-809125.....ADAPTOR FITTING
- 18 41-809131.....CHEMICAL PUMP (Replaced by # 18A)
- 18A 41-809144.....CHEMICAL PUMP (New Style)
- 19 42-809353.....HARDWARE, CLUTCH MOUNTING
- 20 44-802103.....BELT, AP-31
- 20A 44-802236.....BELT, AP-32 (Version "D")
- 21 52-500990.....ELECTRIC CLUTCH
- 22 52-501714.....BUSHING, CLUTCH

- 23 54-500680.....KEY
- 24 54-501640.....SPACER, CLUTCH
- 25 56-500753.....MOUNTING BRACKET, CLUTCH
- 26 56-501985.....ADJUSTING BRACKET, PUMP
- 27 03-000065.....HOSE CLAMP
- 28 03-000113.....HOSE CLAMP
- 29 00-000226.....SCREW, 8mm-1.25mm x 20mm
- 30 00-000237.....SCREW, 8mm-1.25mm x 25mm
- 31 00-000277.....SCREW, 6mm x 20mm
- 32 00-000336.....SCREW, 3/8-16 x 3"
- 33 01-000073.....NUT, 3/8-16
- 34 02-000038.....LOCKWASHER, 1/4
- 35 02-000040.....LOCKWASHER, 5/16
- 36 02-000074.....FLATWASHER, 3/8
- 37 02-000075.....LOCKWASHER, 3/8

NOT SHOWN 05-008016.....OIL, CAT WATER PUMP-21oz.

WATER PUMP DETAIL

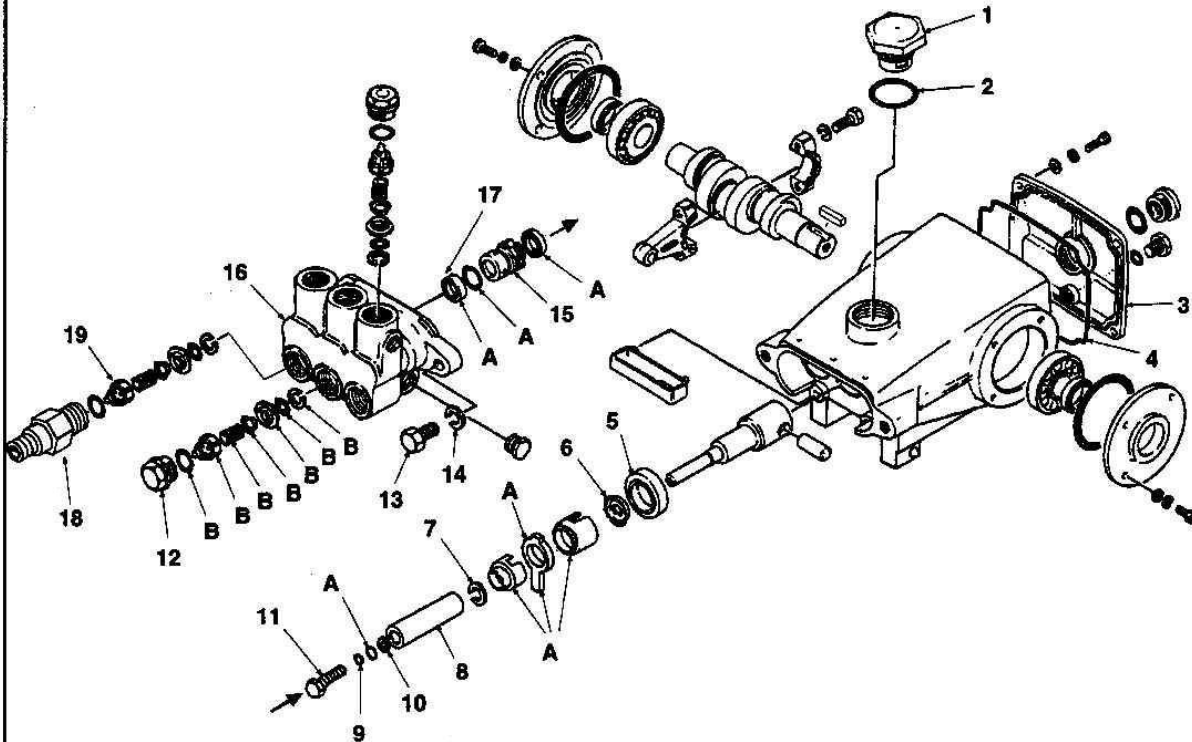

WATER PUMP #61-950776 (3/4" shaft)

- 1 42-809242.....DOMED FILLER CAP
- 2 42-809241.....O-RING, FILLER CAP
- 3 42-809244.....CRANKCASE COVER
- 4 42-809243.....COVER SEAL
- 5 42-809245.....OIL SEAL
- 6 42-809246.....BARRIER SLINGER
- 7 42-809249.....KEYHOLE WASHER M18
- 8 42-809247.....CERAMIC PLUNGER
- 9 42-809248.....COPPER GASKET
- 10 42-809250.....BACK UP RING, PLUNGER
- 11 42-809251.....PLUNGER RETAINER W/ STUD
- 12 42-809253.....VALVE PLUG
- 13 42-809255.....HEX SOCKET BOLT M18X35
- 14 42-809254.....SPLIT LOCKWASHER M10
- 15 42-809252.....SEAL CASE
- 16 42-809259.....MANIFOLD HEAD
- 17 42-809316.....SEAL, HIGH PRESSURE (HI. TEMP.)
- 18 52-809125.....ADAPTOR, CHEMICAL PUMP
- 19 52-809123.....CHECK VALVE, CHEMICAL PUMP PORT
- A 42-809256.....SEAL KIT (must order 3 each of ref. nos. 9 & 10 when replacing all seals)
- B 42-809257.....VALVE KIT (must order 2 valve kits per pump and 1 of ref. no. 19 to replace all check valves)
- C 05-008016.....CAT WATER PUMP OIL

(For additional parts, consult your CAT PUMP manual)

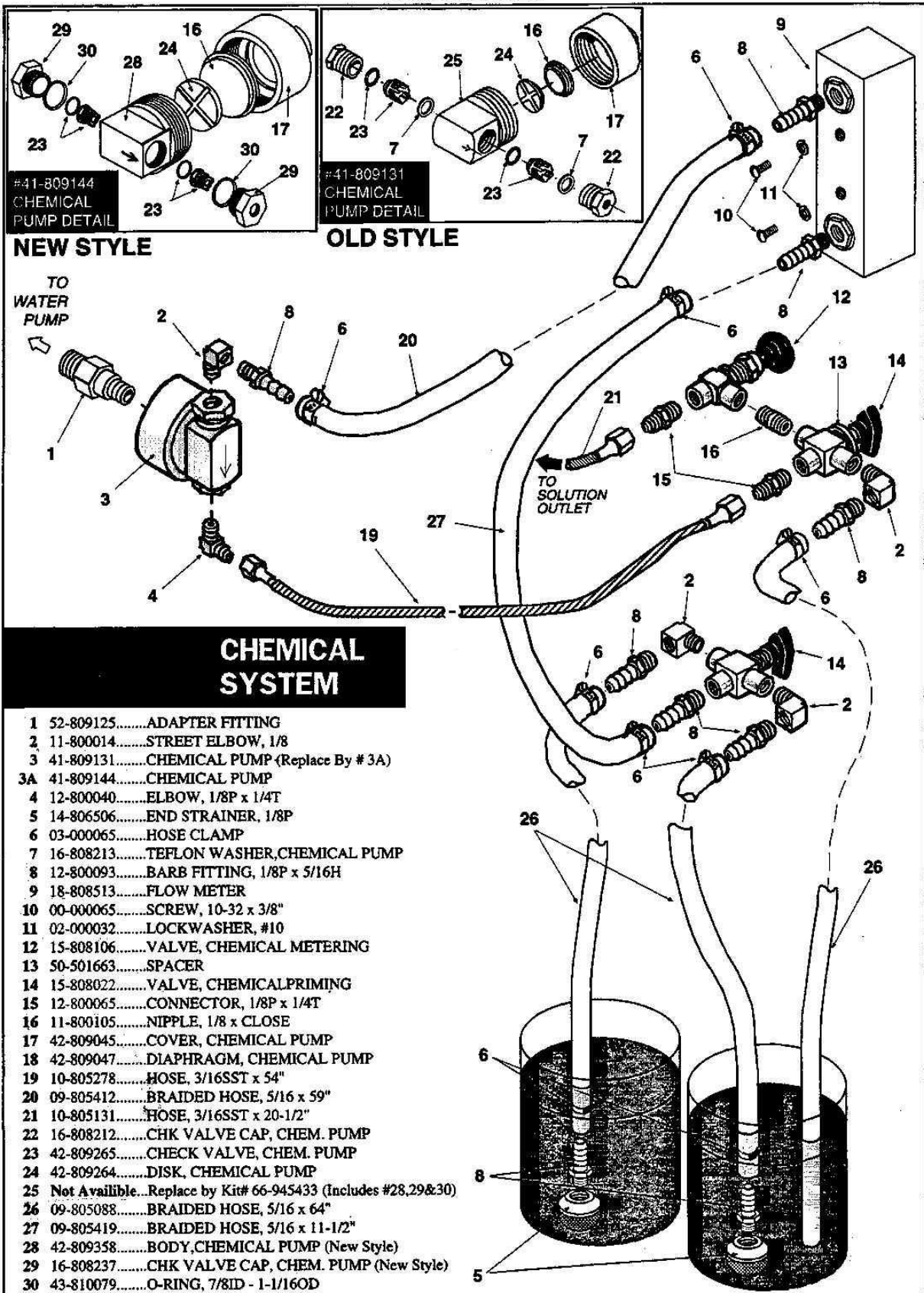

#41-809144
CHEMICAL
PUMP DETAIL

NEW STYLE

#41-809131
CHEMICAL
PUMP DETAIL

OLD STYLE

CHEMICAL SYSTEM

- 1 52-809125.....ADAPTER FITTING
- 2 11-800014.....STREET ELBOW, 1/8"
- 3 41-809131.....CHEMICAL PUMP (Replace By # 3A)
- 3A 41-809144.....CHEMICAL PUMP
- 4 12-800040.....ELBOW, 1/8P x 1/4T
- 5 14-806506.....END STRAINER, 1/8P
- 6 03-000065.....HOSE CLAMP
- 7 16-808213.....TEFLON WASHER, CHEMICAL PUMP
- 8 12-800093.....BARB FITTING, 1/8P x 5/16H
- 9 18-808513.....FLOW METER
- 10 00-000065.....SCREW, 10-32 x 3/8"
- 11 02-000032.....LOCKWASHER, #10
- 12 15-808106.....VALVE, CHEMICAL METERING
- 13 50-501663.....SPACER
- 14 15-808022.....VALVE, CHEMICAL PRIMING
- 15 12-800065.....CONNECTOR, 1/8P x 1/4T
- 16 11-800105.....NIPPLE, 1/8 x CLOSE
- 17 42-809045.....COVER, CHEMICAL PUMP
- 18 42-809047.....DIAPHRAGM, CHEMICAL PUMP
- 19 10-805278.....HOSE, 3/16SST x 54"
- 20 09-805412.....BRAIDED HOSE, 5/16 x 59"
- 21 10-805131.....HOSE, 3/16SST x 20-1/2"
- 22 16-808212.....CHK VALVE CAP, CHEM. PUMP
- 23 42-809265.....CHECK VALVE, CHEM. PUMP
- 24 42-809264.....DISK, CHEMICAL PUMP
- 25 Not Available...Replace by Kit# 66-945433 (Includes #28,29&30)
- 26 09-805088.....BRAIDED HOSE, 5/16 x 64"
- 27 09-805419.....BRAIDED HOSE, 5/16 x 11-1/2"
- 28 42-809358.....BODY, CHEMICAL PUMP (New Style)
- 29 16-808237.....CHK VALVE CAP, CHEM. PUMP (New Style)
- 30 43-810079.....O-RING, 7/8ID - 1-1/16OD

VACUUM EXHAUST HEAT EXCHANGER & SILENCER DETAIL

This manual also covers Lancer units manufactured after Sept. 1996. These units will be identified with a letter "D" stamped after the serial number on the plate, located on the left side as you face unit. Be sure to identify the unit you have prior to ordering parts.

NOTE: View is of the "D" version, older versions may differ slightly.

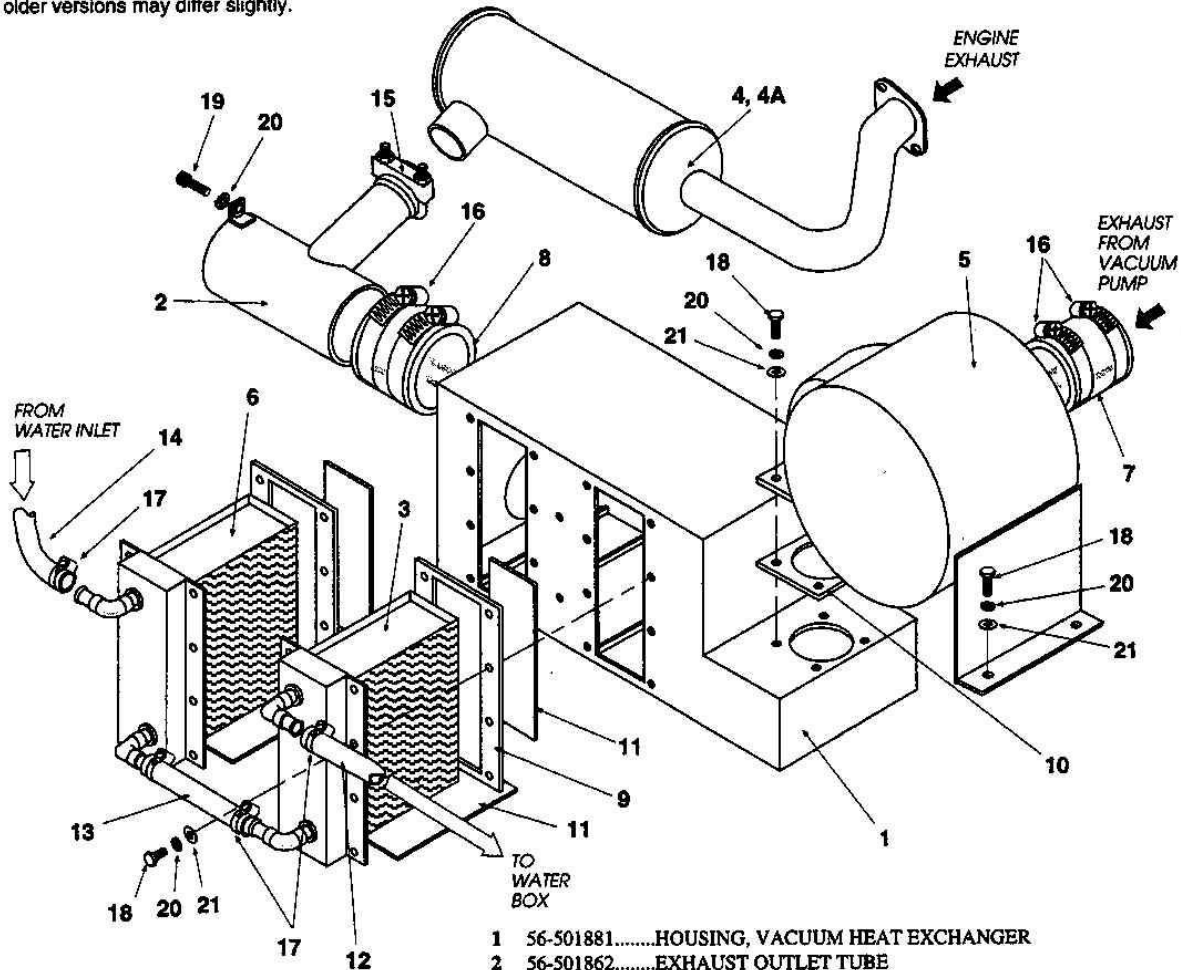

- 1 56-501881.....HOUSING, VACUUM HEAT EXCHANGER
- 2 56-501862.....EXHAUST OUTLET TUBE
- 3 61-950695.....ASSEMBLY, VACUUM PREHEATER CORE (Rear)
- 4 57-520086.....EXHAUST MUFFLER
- 4A 57-520096.....EXHAUST MUFFLER (Version "D")
- 5 57-520082.....VACUUM SILENCER
- 6 61-950696.....ASSEMBLY, VACUUM PREHEATER CORE (Front)
- 7 09-805401.....HOSE, 2-7/8 x 4"
- 8 09-805478.....HOSE, 2-7/8 x 2-1/2"
- 9 43-807084.....GASKET, VACUUM PREHEATER CORE
- 10 43-807080.....GASKET, VACUUM SILENCER
- 11 58-700027.....GASKET, REAR & BOTTOM
- 12 09-805288.....HOSE, 5/8 x 27"
- 13 09-805372.....HOSE, 5/8 x 6-1/2"
- 14 09-805445.....HOSE, 5/8 x 11"
- 15 03-000081.....CLAMP, MUFFLER 1-1/2"
- 16 03-000112.....CLAMP, HOSE #48
- 17 03-000246.....CLAMP, HOSE #8
- 18 00-000055.....SCREW, 1/4-20 x 3/4" HXHD
- 19 00-000210.....SCREW, 1/4-20 x 3/4" SOCHD
- 20 02-000038.....LOCKWASHER, 1/4
- 21 02-000066.....FLATWASHER, 1/4

This manual also covers Lancer units manufactured after Sept. 1996. These units will be identified with a letter "D" stamped after the serial number on the plate, located on the left side as you face unit. Be sure to identify the unit you have prior to ordering parts.

EXHAUST HEAT EXCHANGER ASSEMBLY

CATALYTIC HEAT EXCHANGER ASSEMBLY, PART # 61-950628 (Includes Parts 1 Thru 14)

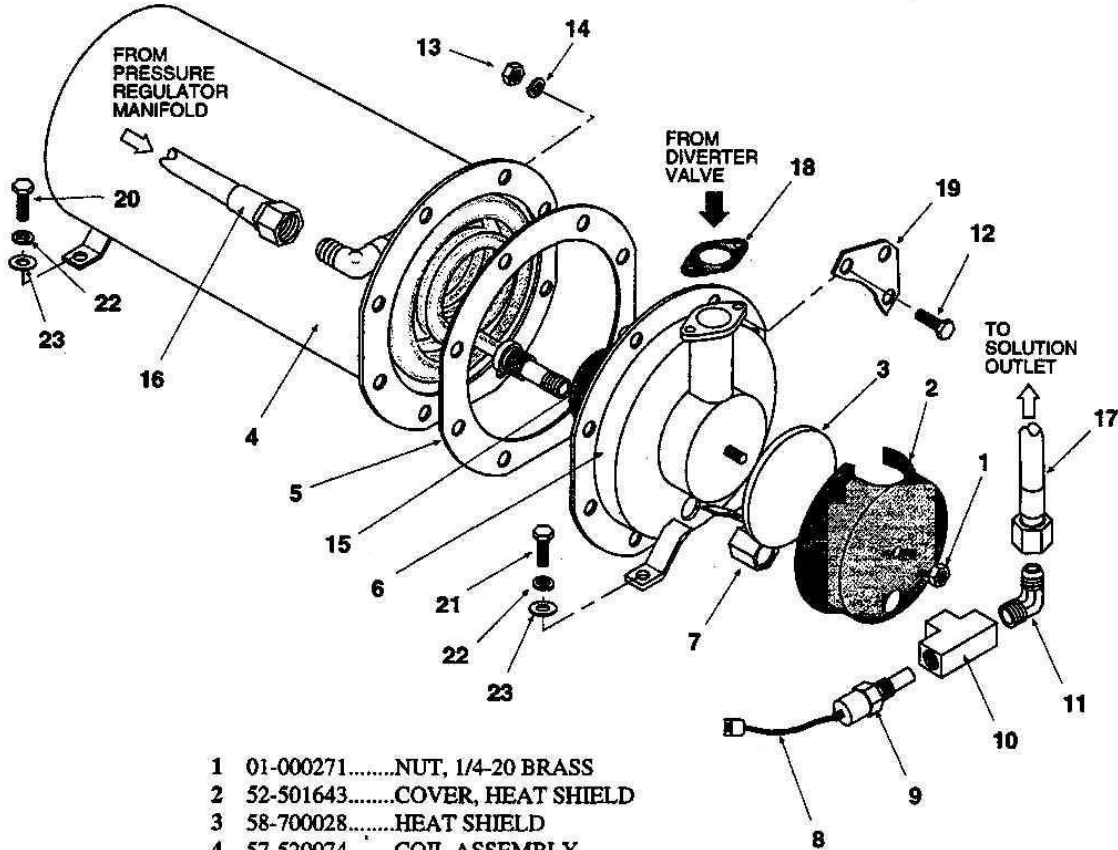

- 1 01-000271.....NUT, 1/4-20 BRASS
- 2 52-501643.....COVER, HEAT SHIELD
- 3 58-700028.....HEAT SHIELD
- 4 57-520074.....COIL ASSEMBLY
- 5 43-807086.....GASKET
- 6 56-501759.....COVER, CATALYTIC (Includes Part# 15)
- 7 52-501654.....NUT, ADAPTOR
- 8 64-950546.....WIRE, TEMPERATURE SENSOR
- 9 35-900184.....TEMPERATURE SENSOR, 285°
- 10 52-501671.....TEE, ADAPTOR
- 11 12-800171.....ELBOW, 1/2P x 1/2T
- 12 00-000019.....SCREW, 1/4-20 x 3/4" HXHD SST
- 13 01-000045.....NUT, 1/4-20 SST
- 14 02-000044.....LOCKWASHER, 1/4 SST
- 15 57-520071.....CATALYTIC CONVERTER (Welded in place)
- 16 10-805275.....HP HOSE, 1/2 x 19"
- 17 10-805376.....HP HOSE, 1/2 x 14-1/2"
- 18 42-902212.....GASKET
- 19 50-501741.....GUIDE, DIVERTER ROD (Prior to Version "D")
- 20 00-000055.....SCREW, 1/4-20 x 3/4" HXHD
- 21 00-000078.....SCREW, 1/4-20 x 1" HXHD
- 22 02-000038.....LOCKWASHER, 1/4
- 23 02-000066.....FLATWASHER, 1/4

SOLUTION OUTLET ASSEMBLY

This manual also covers Lancer units manufactured after mid 1996. These units will be identified with a letter "D" stamped after the serial number on the plate, located on the left side as you face unit. Be sure to identify the unit you have prior to ordering parts.

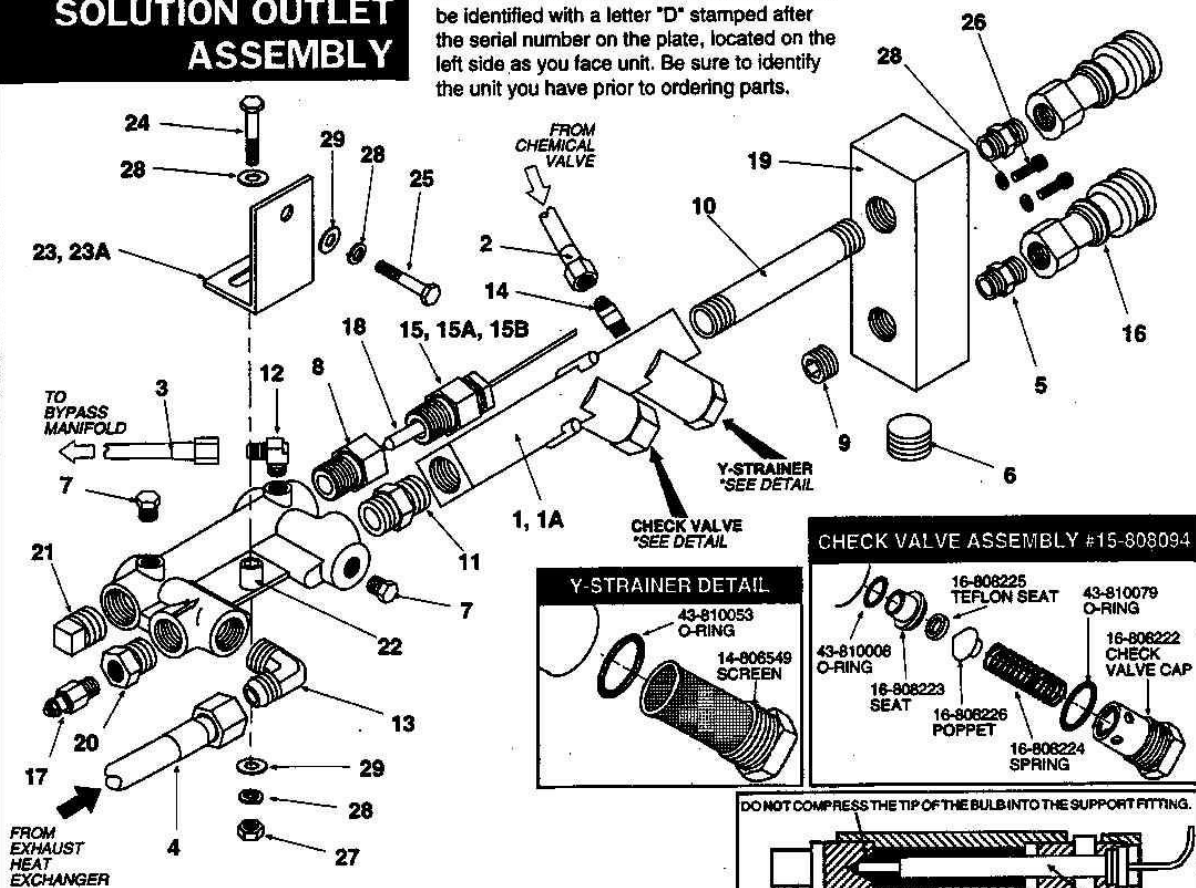

- 1 15-808095.....CHECK VALVE MANIFOLD ASSY (Includes Y-Strainer & Check Valve)
- 1A 52-501621.....CHECK VALVE MANIFOLD
- 2 10-805288.....HOSE, 3/16SST x 17"
- 3 10-805204.....HOSE, 3/16SST x 23"
- 4 10-805376.....HOSE, 1/2 x 14-1/2"
- 5 11-800029.....NIPPLE, HEX 1/4
- 6 11-800069.....PLUG, 1/2 SOCHD
- 7 11-800101.....PLUG, 1/8
- 8 11-800342.....CONNECTOR, 1/2P x 1/2FP
- 9 11-800345.....PLUG, 1/4 SOCHD
- 10 11-800426.....NIPPLE, 3/8 x 5" sst
- 11 11-800429.....NIPPLE, HEX 3/8 sst
- 12 12-800040.....EL BOW, 1/8P x 1/4T
- 13 12-800225.....ELBOW, 3/8P x 1/2T
- 14 12-800261.....ELBOW, 1/8P x 1/4T (45°)
- 15 12-800130.....UNION, TEMP. SENSOR (Old Style)
- 15A 66-810030.....SEAL KIT, TEMPERATURE PROBE (for Old Style ONLY)
- 15B 12-800391.....CAPILLARY UNION, TEMPERATURE PROBE (New Style)
- 16 13-806001.....DISCONNECT, 1/4F x 1/4FP
- 17 34-903019.....SENSOR, TEMPERATURE GAUGE
- 18 35-900182.....TEMPERATURE CONTROL
- 19 52-501653.....MANIFOLD, SOLUTION OUTLET
- 20 52-501669.....BUSHING, TEMPERATURE SENSOR
- 21 52-501680.....SUPPORT FITTING
- 22 52-501700.....THERMOSTAT MANIFOLD
- 23 56-501884.....MOUNTING BRACKET
- 23A 56-502118.....MOUNTING BRACKET (Version "D")
- 24 00-000132.....SCREW, 1/4-20 x 1-1/2" HXHD
- 25 00-000142.....SCREW, 1/4-20 x 2-1/2" HXHD
- 26 00-000210.....SCREW, 1/4-20 x 3/4" SOCHD
- 27 01-000037.....NUT, 1/4-20
- 28 02-000038.....LOCKWASHER, 1/4
- 29 02-000066.....FLATWASHER, 1/4

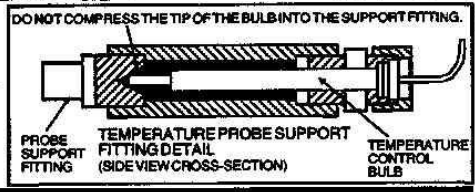
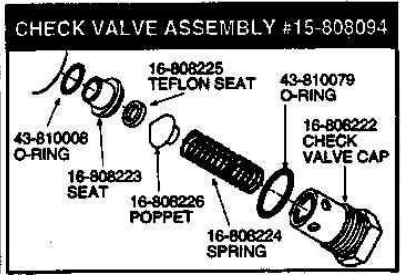
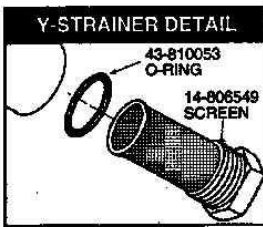

OLD STYLE

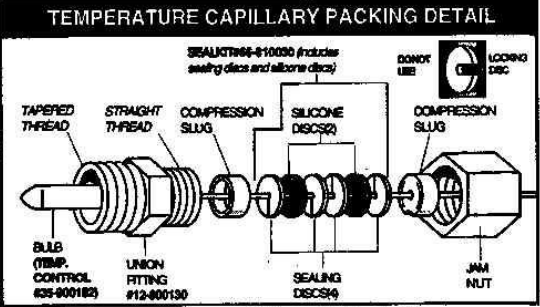

NEW STYLE

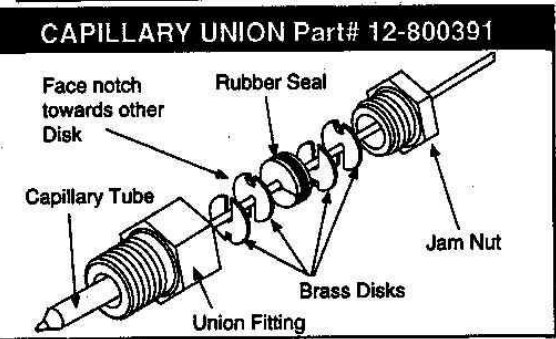

WATER BOX ASSEMBLY

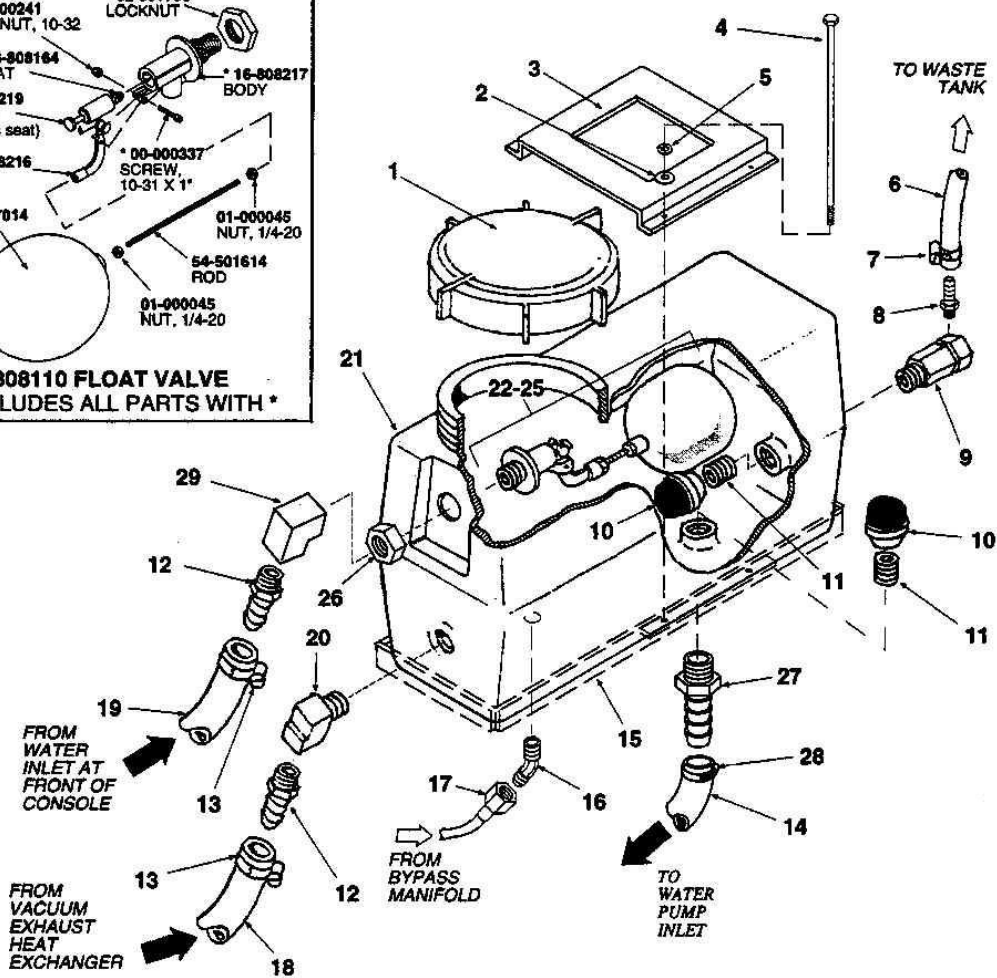
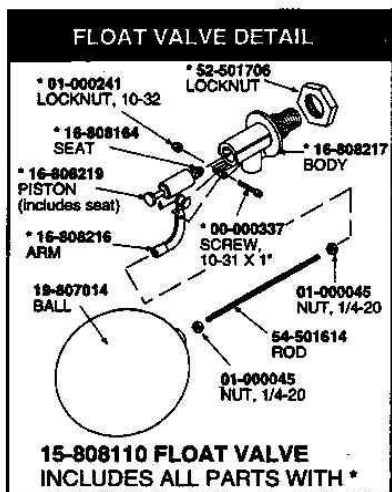

- | | | | |
|----|--|-----|---|
| 1 | 11-800432.....COVER, WATER BOX | 17 | 10-805294.....HOSE, 3/16SST x 11-1/2" |
| 2 | 02-000066.....FLATWASHER, 1/4 | 18 | 09-805265.....HOSE, 5/8 x 24" |
| 3 | 50-501763.....HOLD DOWN | 19 | 09-805446.....HOSE, 5/8 x 55" |
| 4 | 00-000335.....SCREW, 1/4-20 x 8" | 20 | 11-800041.....STREET ELBOW, 1/2 |
| 5 | 02-000038.....LOCKWASHER, 1/4 | 21 | 58-500677.....WATER BOX 58-500781 |
| 6 | 09-805099.....HOSE, 5/16 x 40" | 22 | 15-808110.....VALVE, FLOAT |
| 7 | 03-000065.....HOSE CLAMP | 22A | 16-808217.....BODY, FLOAT VALVE |
| 8 | 12-800093.....BARB FITTING, 1/8P x 5/16H | 22B | 16-808219.....PISTON, FLOAT VALVE |
| 9 | 15-808083.....VALVE, TEMP REL 180° | 22C | 16-808216.....ARM, FLOAT VALVE |
| 10 | 14-806540.....STRAINER, SUC END 1/2FP | 23 | 01-000045.....NUT, 1/4-20 SST |
| 11 | 11-800300.....NIPPLE, 1/2 x CL | 24 | 54-501614.....ROD, FLOAT |
| 12 | 12-800269.....BARB FITTING, 1/2P x 5/8H | 25 | 19-807014.....BALL, FLOAT |
| 13 | 03-000246.....HOSE CLAMP #8 | 26 | 52-501706.....LOCKNUT, FLOAT VALVE |
| 14 | 09-805435.....HOSE, 3/4 x 33" | 27 | 12-800278.....BARB FITTING, 1/2P x 3/4H |
| 15 | 56-501902.....TRAY, WATER BOX | 28 | 03-000111.....HOSE CLAMP #10 |
| 16 | 12-800356.....45° ELBOW, 1/4P x 1/4T | 29 | 11-800361.....ELBOW, 1/2 |

PRESSURE REGULATOR MANIFOLD ASSEMBLY

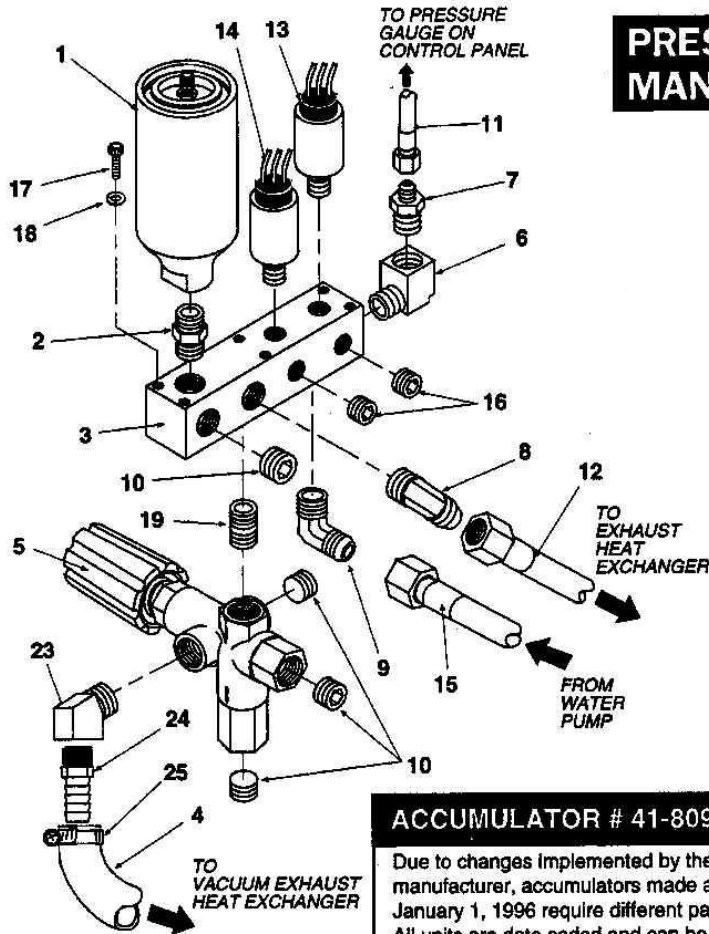

- 1 41-809119.....ACCUMULATOR
- 2 11-800429.....HEX NIPPLE, 3/8 sst
- 3 52-501682.....MANIFOLD
- 4 10-805445.....HOSE, 5/8 x 11"
- 5 15-808068.....PRESSURE REGULATOR
- 6 11-800275.....STREET ELBOW, 3/8
- 7 12-800346.....CONNECTOR, 3/8P x 1/4T
- 8 12-800347.....ELL, 3/8 x 1/2T (45°)
- 9 12-800225.....ELL, 3/8P x 1/2T
- 10 11-800224.....PLUG, 3/8
- 11 10-805362.....HOSE, 3/16SST x 16-1/2"
- 12 10-805275.....HOSE, 1/2 x 19"
- 13 32-900186.....HIGH PRESSURE SWITCH
- 14 32-900184.....LOW PRESSURE SWITCH
- 15 10-805317.....HOSE, HP 3/8 x 37"
- 16 11-800345.....PLUG, 1/4
- 17 00-000210.....SCREW, 1/4-20 x 3/4"
- 18 02-000038.....LOCKWASHER, 1/4
- 19 11-800368.....NIPPLE, 3/8 x CLOSE sst
- 20 16-808201.....KIT, O-RING
- 21 43-810078.....O-RING, VITON
- 22 16-808200.....KIT, VALVE
- 23 11-800341.....ELL, STREET 3/8 (45°)
- 24 12-800345.....FTTG, BARB 3/8P x 5/8H
- 25 03-000246.....CLAMP, HOSE #8

ACCUMULATOR # 41-809119

Due to changes implemented by the manufacturer, accumulators made after January 1, 1996 require different parts. All units are date coded and can be identified by a two letter marking as noted in the detail. Identify the unit prior to ordering parts. The first letter identifies the month and the second the year it was manufactured.

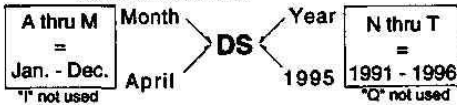

PART NUMBERS

Units Manufactured Before Jan. 1 1996

- Snap Ring ----- 42-809273
- Top ----- 42-809272
- Valve Assembly ----- 42-809274
- Bladder ----- 42-809275
- Body ----- Not Available

Units Manufactured After Jan. 1 1996

- Snap Ring ----- 42-809362
- Top ----- 42-809363
- Valve Assembly ----- 42-809274
- Bladder ----- 42-809275
- Body ----- Not Available

Rebuilding and repressurising should only be done at a facility with the proper equipment and qualified personnel to do so. Pre-charge with nitrogen to 250 PSI. The pre-charge should be checked at least once a year.

Do Not pre-charge accumulator above 250 PSI.

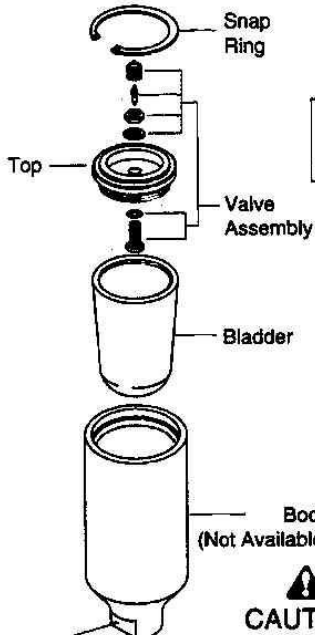

Identifying Mark will be stamped here.

CAUTION:

PRESSURE REGULATOR DETAIL #15-808068

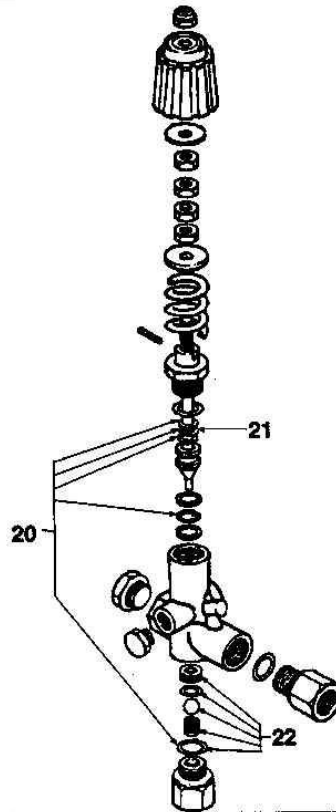

TEMPERATURE SOLENOID & BYPASS MANIFOLD ASSEMBLY

This manual also covers Lancer units manufactured after Sept. 1996. These units will be identified with a letter "D" stamped after the serial number on the plate, located on the left side as you face unit. Be sure to identify the unit you have prior to ordering parts.

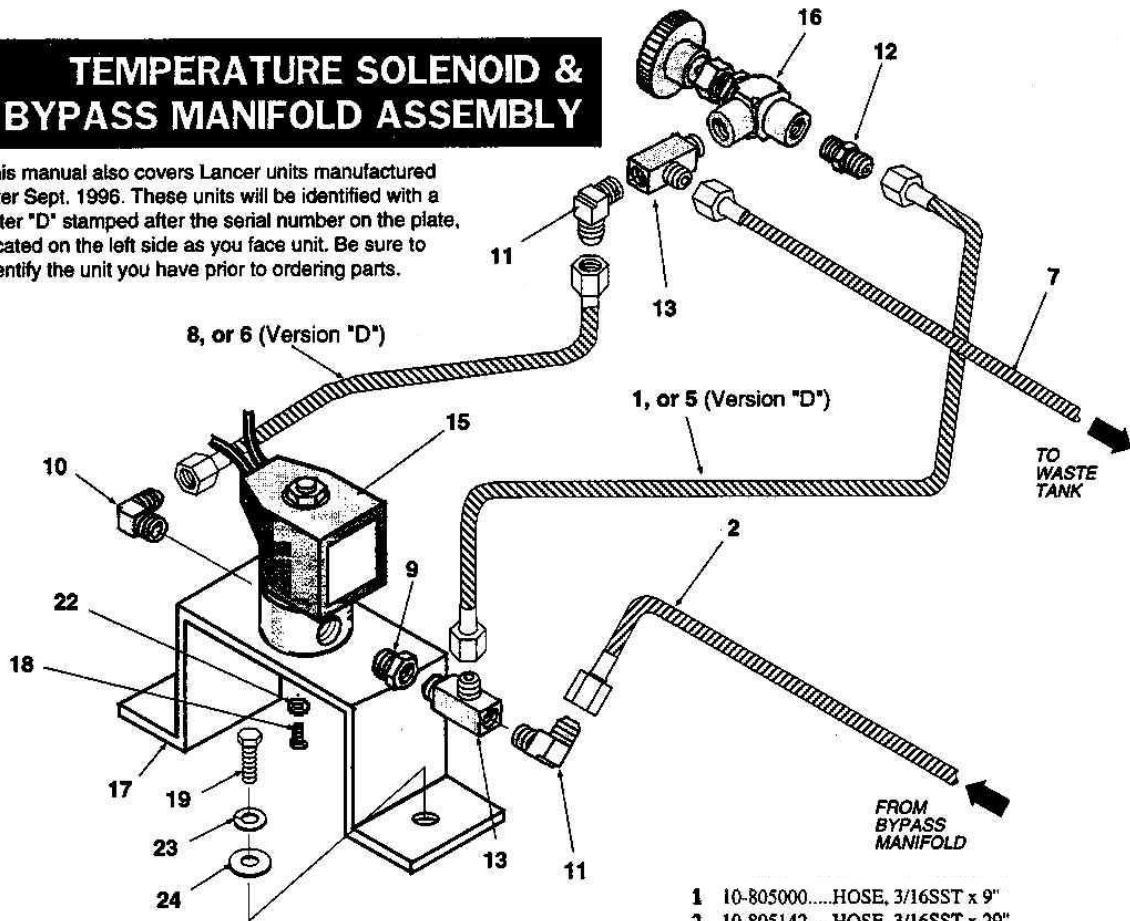

#15-808111 BYPASS MANIFOLD DETAIL

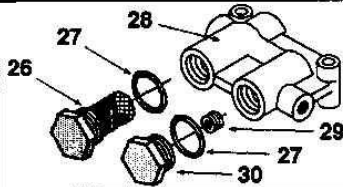

#66-945280 BYPASS MAINTENANCE KIT IS AVAILABLE. THIS CONTAINS THE TOOLS NECESSARY TO DISASSEMBLE AND REASSEMBLE THE INTERIOR PARTS OF THE BYPASS MANIFOLD AND TEMPERATURE SOLENOID.

BYPASS MANIFOLD ASSEMBLY

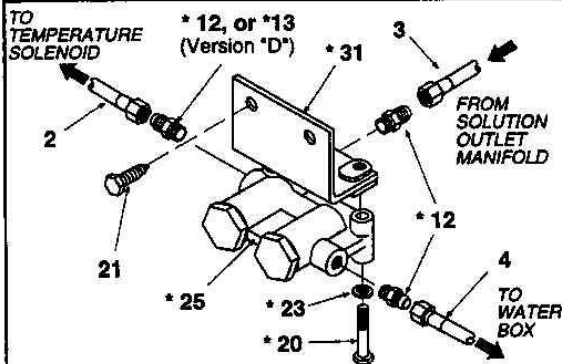

61-950692 BYPASS MANIFOLD ASSEMBLY INCLUDES ALL PARTS WITH *

- 1 10-805000.....HOSE, 3/16SST x 9"
- 2 10-805142.....HOSE, 3/16SST x 29"
- 3 10-805204.....HOSE, 3/16SST x 23"
- 4 10-805294.....HOSE, 3/16SST x 11-1/2"
- 5 10-805311.....HOSE, 3/16SST x 10-1/2"
- 6 10-805355.....HOSE, 3/16SST x 8"
- 7 10-805363.....HOSE, 3/16SST x 63-1/2"
- 8 10-805366.....HOSE, 3/16SST x 6"
- 9 11-800039.....BUSHING, 1/4P x 1/8FP
- 10 12-800031.....ELBOW, 1/4P x 1/4T
- 11 12-800040.....ELBOW, 1/8P x 1/4T
- 12 12-800065.....CONNECTOR, 1/8P x 1/4T
- 13 12-800088.....TEE, 1/8P x 1/4T x 1/8FP
- 14 12-800261.....ELBOW, 1/8P x 1/4T (45°)
- 15 15-808105.....TEMPERATURE SOLENOID
- 16 15-808107..... VALVE, TEMPERATURE BYPASS
- 17 50-501744.....BRACKET, SOLENOID MOUNTING
- 18 00-000065.....SCREW, 10-32 x 3/8" PANHD
- 19 00-000055.....SCREW, 1/4-20 x 3/4" HXHD
- 20 00-000132.....SCREW, 1/4-20 x 1-1/2" HXHD
- 21 00-000255.....SCREW, SELFDRIVE #14 x 1" HXHD
- 22 02-000032.....LOCKWASHER, #10
- 23 02-000038.....LOCKWASHER, 1/4
- 24 02-000066.....FLATWASHER, 1/4
- 25 15-808111.....BYPASS MANIFOLD ASSEMBLY
- 26 14-806552.....SCREEN, BYPASS MANIFOLD
- 27 43-810053.....O-RING, BYPASS MANIFOLD
- 28 52-501659.....BLOCK, BYPASS MANIFOLD
- 29 52-501665.....BYPASS ORIFICE
- 30 53-501523.....CAP, BYPASS MANIFOLD
- 31 56-501906.....BRACKET, BYPASS MANIFOLD

EXHAUST DIVERTER ASSEMBLY

PRIOR TO VERSION "D"

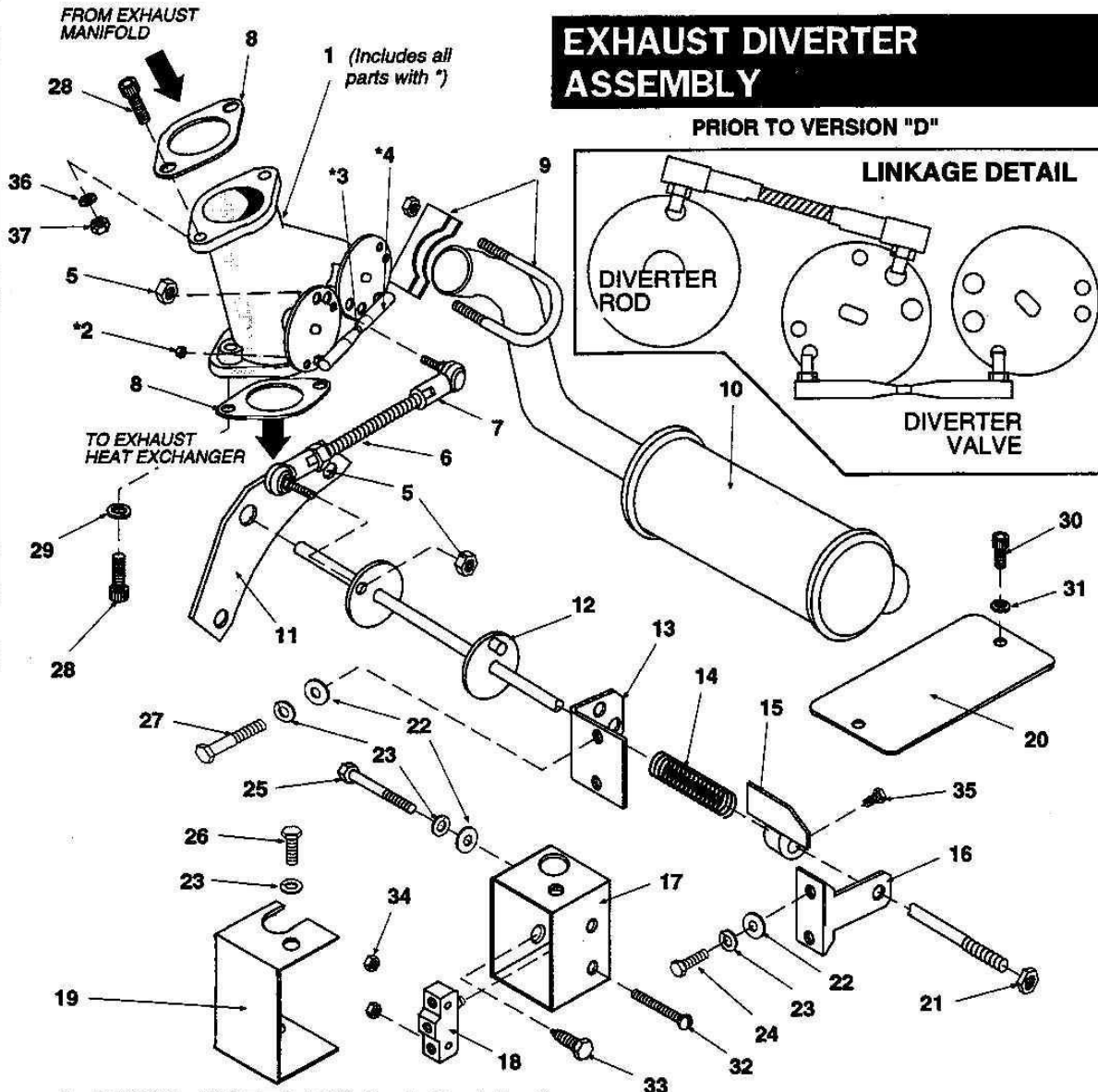

- | | | | |
|----|--|----|--|
| 1 | 61-950697.....DIVERTER ASSY. (Includes Parts 1 Thru 4) | 20 | 50-501782.....COVER, THERMOSTAT |
| 2 | 01-000019.....LOCKNUT, 10-32 | 21 | 01-000272.....JAMNUT, 3/8-16 |
| 3 | 54-501625.....ROD, 10-32 x 3/4" | 22 | 02-000066.....FLATWASHER, 1/4 |
| 4 | 04-000292.....SWIVEL LINKAGE | 23 | 02-000038.....LOCKWASHER, 1/4 |
| 5 | 01-000230.....LOCKNUT, 1/4-28 | 24 | 00-000055.....SCREW, 1/4-20 x 3/4" |
| 6 | 54-501631.....CONNECTOR ROD | 25 | 00-000142.....SCREW, 1/4-20 x 2-1/2" |
| 7 | 04-000284.....ROD END (SPHER) | 26 | 00-000070.....SCREW, 1/4-20 x 1/2" |
| 8 | 42-902212.....GASKET, EXHAUST | 27 | 00-000122.....SCREW, 1/4-20 x 1-3/4" |
| 9 | 03-000082.....MUFFLER CLAMP, 1-1/2" | 28 | 00-000315.....SCREW, 5/16-18 x 7/8" SOCHD |
| 10 | 57-520086.....EXHAUST MUFFLER | 29 | 02-000274.....LOCKWASHER, 5/16 (SOCKET HD) |
| 11 | 50-501741.....GUIDE, DIVERTER ROD | 30 | 00-000071.....SCREW, 10-24 x 1/2" |
| 12 | 56-502071.....DIVERTER ROD | 31 | 02-000032.....LOCKWASHER, #10 |
| 13 | 56-501882.....DIVERTER ROD GUIDE (Rear) | 32 | 00-000014.....SCREW, 6-32 x 1" |
| 14 | 04-000286.....SPRING, DIVERTER ROD | 33 | 00-000255.....SCREW, SELFDRIIVE #14 x 1" |
| 15 | 56-501761.....ACTIVATING LEVER | 34 | 01-000059.....LOCKNUT, 6-32 |
| 16 | 56-501772.....DIVERTER ROD GUIDE (Front) | 35 | 00-000342.....SCREW, 5/16-24 x 3/8" |
| 17 | 56-501770.....SWITCH MOUNTING BRACKET | 36 | 02-000040.....LOCKWASHER, 5/16 |
| 18 | 35-900180.....MICROSWITCH | 37 | 01-000041.....NUT, 5/16-18 |
| 19 | 50-501689.....COVER, SWITCH BRACKET | | |

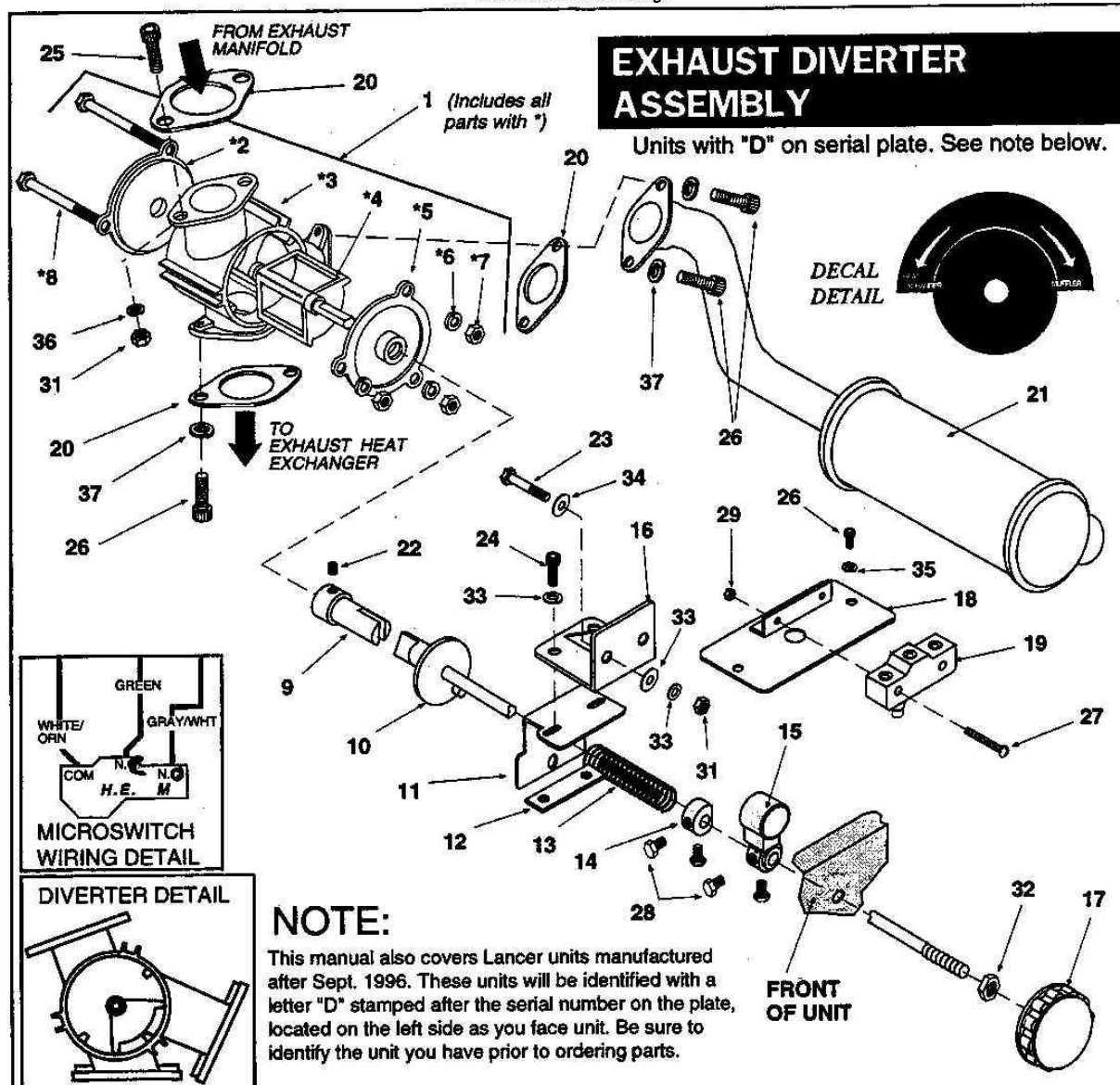

NOTE:

This manual also covers Lancer units manufactured after Sept. 1996. These units will be identified with a letter "D" stamped after the serial number on the plate, located on the left side as you face unit. Be sure to identify the unit you have prior to ordering parts.

- | | |
|--|---|
| <p>1 61-950885.....DIVERTER ASSY. (Includes Parts 2 Thru 8)</p> <p>2 52-501743.....CAP, DIVERTER VALVE</p> <p>3 52-501741.....BODY, DIVERTER VALVE</p> <p>4 58-500752.....DIVERTER</p> <p>5 52-501762.....CAP, FRONT-DIVERTER VALVE</p> <p>6 02-000044.....LOCKWASHER, 1/4 sst</p> <p>7 01-000045.....NUT, 1/4-20 sst</p> <p>8 00-000383.....SCREW, 1/4-20 x 2-1/4" sst</p> <p>9 52-501788.....DIVERTER CONNECTOR LINKAGE-F</p> <p>10 56-502137.....DIVERTER ROD LINKAGE-M</p> <p>11 50-501880.....DIVERTER ROD GUIDE (Rear)</p> <p>12 56-502136.....HOLD DOWN, DIVERTER ROD GUIDE</p> <p>13 04-000286.....SPRING, DIVERTER ROD</p> <p>14 53-501525.....STOP, CRANK ARM</p> <p>15 56-502114.....ACTIVATING LEVER</p> <p>16 56-502115.....BRACKET, SUPPORT-ROD GUIDE (Rear)</p> <p>17 04-000285.....HANDLE, EXHAUST DIVERTER VALVE</p> <p>18 56-502108.....BRACKET, MICROSWITCH MOUNT</p> <p>19 35-900180.....MICROSWITCH</p> | <p>20 42-902212.....GASKET, EXHAUST</p> <p>21 57-520096.....EXHAUST MUFFLER</p> <p>22 00-000265.....SET SCREW, 1/4-20 x 1/2"</p> <p>23 00-000132.....SCREW, 1/4-20 x 1-1/2"</p> <p>24 00-000210.....SCREW, 1/4-20 x 3/4" SOCHD</p> <p>25 00-000315.....SCREW, 5/16-18 x 7/8" SOCHD</p> <p>26 00-000071.....SCREW, 10-24 x 1/2"</p> <p>27 00-000014.....SCREW, 6-32 x 1"</p> <p>28 00-000342.....SCREW, 5/16-24 x 3/8"</p> <p>29 01-000059.....LOCKNUT, 6-32</p> <p>30 01-000037.....NUT, 1/4-20</p> <p>31 01-000041.....NUT, 5/16-18</p> <p>32 01-000272.....JAMNUT, 3/8-16</p> <p>33 02-000038.....LOCKWASHER, 1/4</p> <p>34 02-000066.....FLATWASHER, 1/4</p> <p>35 02-000032.....LOCKWASHER, #10</p> <p>36 02-000040.....LOCKWASHER, 5/16</p> <p>37 02-000274.....LOCKWASHER, 5/16 (SOCKET HD)</p> |
|--|---|

AIR PUMP PARTS DETAIL

This manual also covers Lancer units manufactured after Sept. 1996. These units will be identified with a letter "D" stamped after the serial number on the plate, located on the left side as you face unit. Be sure to identify the unit you have prior to ordering parts.

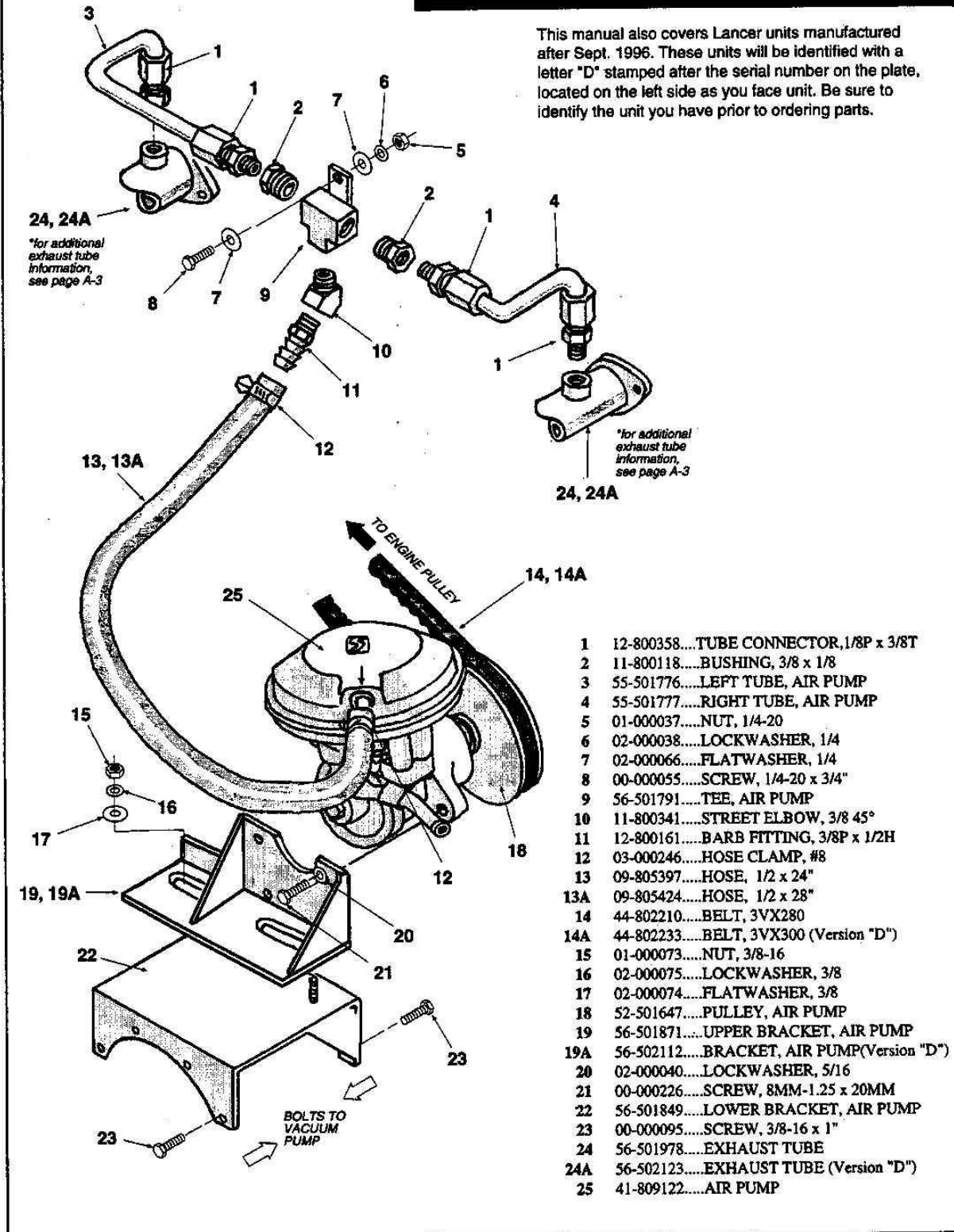

- 1 12-800358.....TUBE CONNECTOR, 1/8P x 3/8T
- 2 11-800118.....BUSHING, 3/8 x 1/8
- 3 55-501776.....LEFT TUBE, AIR PUMP
- 4 55-501777.....RIGHT TUBE, AIR PUMP
- 5 01-000037.....NUT, 1/4-20
- 6 02-000038.....LOCKWASHER, 1/4
- 7 02-000066.....FLATWASHER, 1/4
- 8 00-000055.....SCREW, 1/4-20 x 3/4"
- 9 56-501791.....TEE, AIR PUMP
- 10 11-800341.....STREET ELBOW, 3/8 45°
- 11 12-800161.....BARB FITTING, 3/8P x 1/2H
- 12 03-000246.....HOSE CLAMP, #8
- 13 09-805397.....HOSE, 1/2 x 24"
- 13A 09-805424.....HOSE, 1/2 x 28"
- 14 44-802210.....BELT, 3VX280
- 14A 44-802233.....BELT, 3VX300 (Version "D")
- 15 01-000073.....NUT, 3/8-16
- 16 02-000075.....LOCKWASHER, 3/8
- 17 02-000074.....FLATWASHER, 3/8
- 18 52-501647.....PULLEY, AIR PUMP
- 19 56-501871.....UPPER BRACKET, AIR PUMP
- 19A 56-502112.....BRACKET, AIR PUMP (Version "D")
- 20 02-000040.....LOCKWASHER, 5/16
- 21 00-000226.....SCREW, 8MM-1.25 x 20MM
- 22 56-501849.....LOWER BRACKET, AIR PUMP
- 23 00-000095.....SCREW, 3/8-16 x 1"
- 24 56-501978.....EXHAUST TUBE
- 24A 56-502123.....EXHAUST TUBE (Version "D")
- 25 41-809122.....AIR PUMP

WASTE TANK ASSEMBLY

WASTE TANK ASSEMBLY Part #63-950394
WASTE TANK ASSEMBLY Part #63-950409 (Version "D").

This manual also covers Lancer units manufactured after Sept. 1996. These units will be identified with a letter "D" stamped after the serial number on the plate, located on the left side as you face unit. Be sure to identify the unit you have prior to ordering parts.

61-950621 FLOAT SWITCH REPLACEMENT PARTS

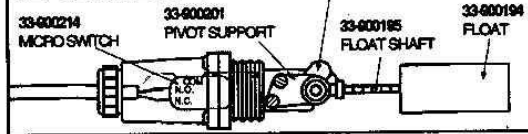

*For Optional Waste Pump-Out Parts Listing See Page A-18

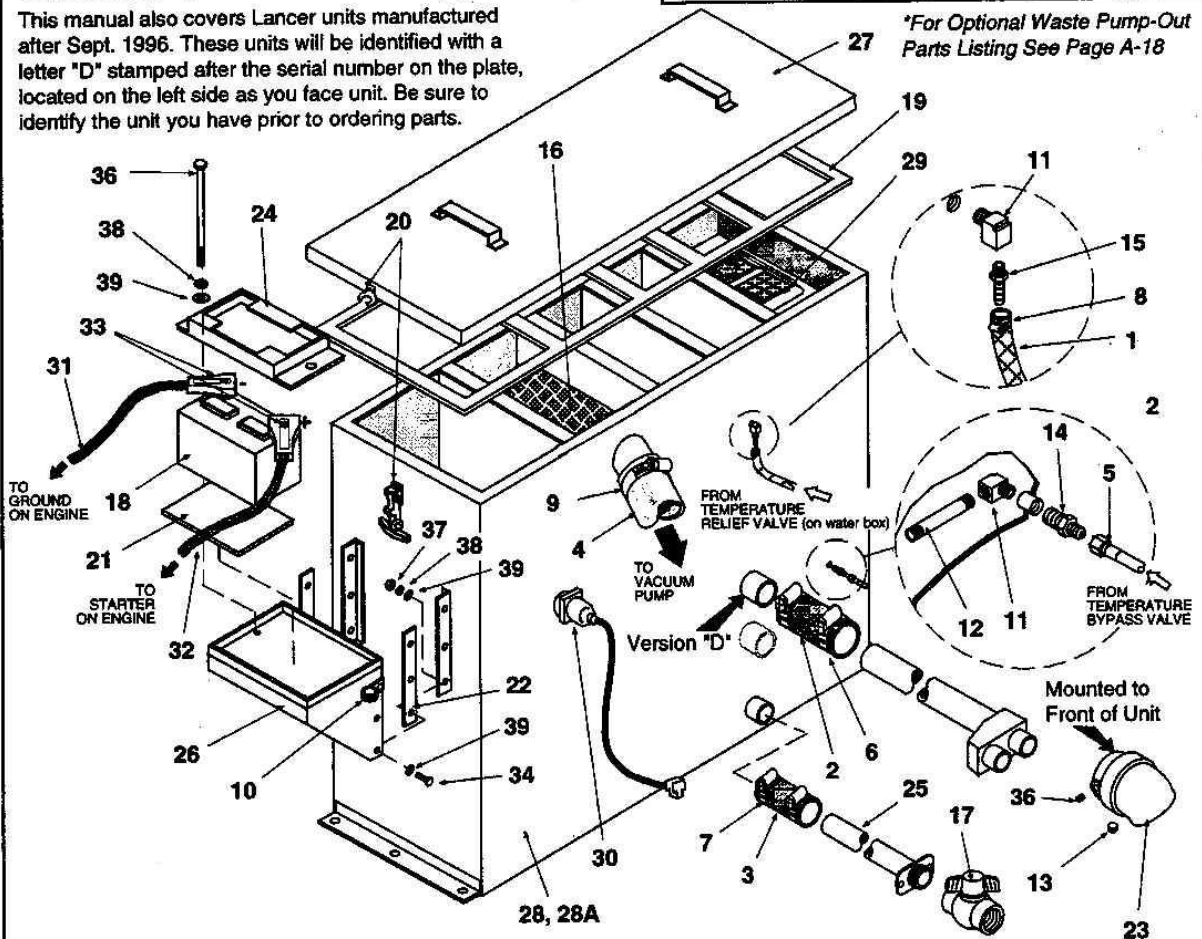

- | | |
|---|--|
| 1 09-805099.....HOSE, 5/16 x 40" | 22 50-501697.....SPACER, BATTERY MOUNT |
| 2 09-805143.....HOSE, 2-1/2 x 6-1/2" | 23 52-501681.....DIVERTER, VACUUM EXHAUST |
| 3 09-805339.....HOSE, 2" x 7" | 24 56-500188.....HOLD-DOWN, BATTERY |
| 4 09-805341.....HOSE, 2-7/8 x 25" | 25 56-501686.....WASTE OUTLET TUBE |
| 5 10-805363.....HOSE, 3/16SST x 63-1/2" | 26 56-501779.....MOUNT, BATTERY |
| 6 03-000000.....CLAMP, HOSE #40 | 27 56-501788.....LID, WASTE TANK |
| 7 03-000054.....CLAMP, HOSE #32 | 28 56-501792.....WASTE TANK (tank only) |
| 8 03-000065.....CLAMP, HOSE #4 | 28A 56-501947.....WASTE TANK (tank only-Version "D") |
| 9 03-000112.....CLAMP, HOSE #48 | 29 56-501793.....STRAINER BASKET |
| 10 03-000242.....CABLE CLAMP | 30 61-950621.....ENGINE SHUTOFF SWITCH |
| 11 11-800045.....ELBOW, STREET 1/4 | 31 64-950515.....BATTERY CABLE x 111" (Black) |
| 12 11-800404.....NIPPLE, 1/4 x 5" sst | 32 64-950521.....BATTERY CABLE x 108" (Red) |
| 13 11-800422.....PLUG, 1/8 | 33 31-900179.....BATTERY TERMINAL COVERS |
| 14 12-800060.....CONNECTOR, 1/4P x 1/4T | 34 00-000078.....SCREW, 1/4-20 x 1" HXHD |
| 15 12-800092.....FITTING, BARB 1/4P x 5/16H | 35 00-000167.....SCREW, 1/4-20 x 6" HXHD |
| 16 14-806518.....STRAINER | 36 00-000265.....SCREW, SET 1/4-20 x 1/2" SOCHD |
| 17 15-808080.....VALVE, WASTE OUTLET | 37 01-000037.....NUT, 1/4-20 |
| 18 36-900056.....BATTERY | 38 02-000038.....LOCKWASHER, 1/4 |
| 19 43-807094.....GASKET, WASTE TANK LID | 39 02-000066.....FLATWASHER, 1/4 |
| 20 46-802510.....DRAW LATCH | |
| 21 47-700007.....HEAT SHIELD | |
- NOT SHOWN 05-008002.....GASKET ADHESIVE (10.3oz. Tube)

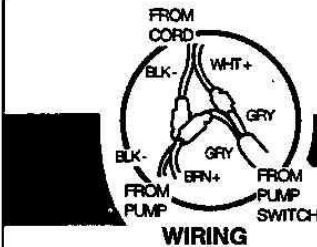
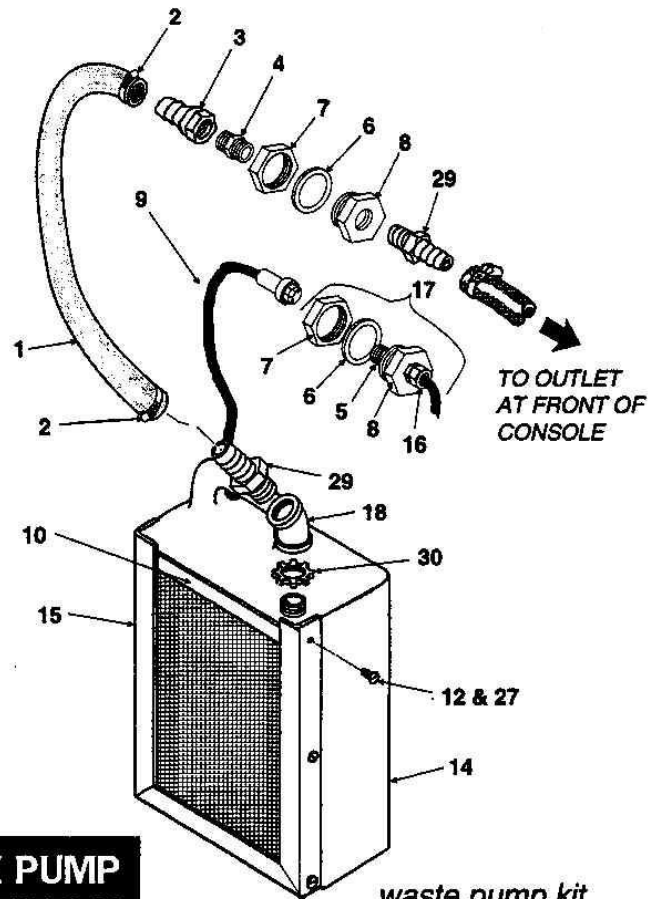
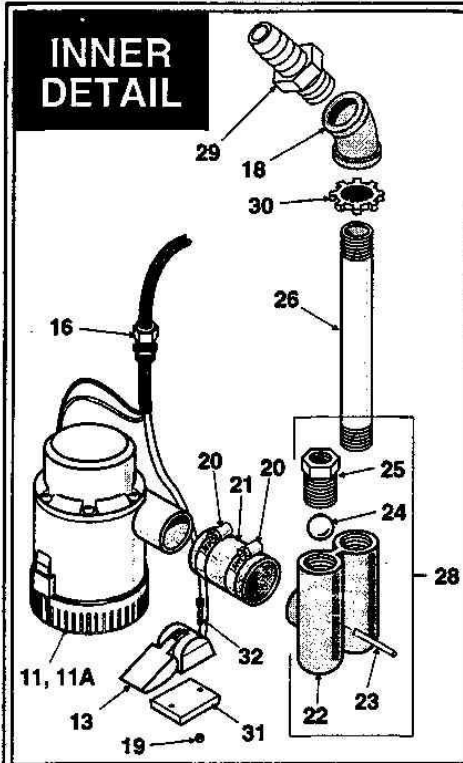

WASTE PUMP ASSEMBLY

waste pump kit #66-945193

- 1 09-805436.....HOSE 3/4 x 21"
- 2 03-000111.....CLAMP, HOSE #10
- 3 12-800370.....FITTING, BARB 3/4 HOS SWIV x 3/4H
- 4 12-800051.....HOSE CONNECTOR, 3/4
- 5 31-900198.....CORD CONNECTOR
- 6 43-807092.....SEAL
- 7 52-501651.....NUT
- 8 52-501649.....CORD FITTING
- 9 31-900197.....CORD
- 10 14-806550.....SCREEN
- 11 41-809128.....WASTE PUMP
- 11A 42-809267.....SCREEN, WASTE PUMP (Plastic)
- 12 00-000210.....SCREW, 1/4-20 x 3/4" sst
- 13 32-900183.....FLOAT SWITCH
- 14 58-500643.....ENCLOSURE
- 15 50-501706.....STRAINER GUIDE
- 16 31-900194.....STRAIN RELIEF
- 17 64-950541.....CORD ASSEMBLY (Includes Parts 5,6,7,8,& 16)
- 18 11-800434.....ELBOW, 3/4 (45°)
- 19 01-000241.....LOCKNUT, 10-32 sst
- 20 03-000110.....HOSE CLAMP #24
- 21 08-805262.....CUFF
- 22 52-501662.....BODY, VALVE
- 23 04-000290.....PIN
- 24 04-000291.....BALL, NYLON
- 25 52-501666.....SEAT, VALVE
- 26 11-800419.....NIPPLE, 3/4 x 6-5/8"
- 27 01-000023.....NUT, 1/4-20
- 28 15-808101.....ASSY, CHECK VALVE (Includes Parts 22 thru 25)
- 29 12-800095.....FITTING, BARB, 3/4P x 3/4H
- 30 01-000119.....LOCKNUT, 3/4NPT
- 31 50-501730.....SPACER
- 32 00-000317.....SCREW, 10-32 x 1-1/4"
- 33 66-950412.....WASTE OUTLET ASSEMBLY

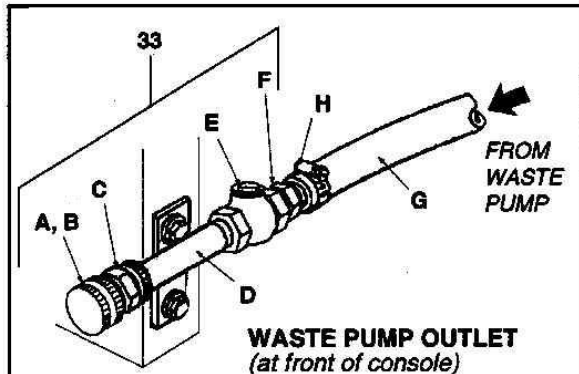

- A 12-800052 END CAP
- B 43-807008 END CAP WASHER
- C 12-800360 HOSE CONNECTOR FITTING
- D 56-501794 OUTLET NIPPLE & BRACKET
- E 15-808065 SWING CHECK VALVE
- F 12-800095 FITTING, BARB 3/4P x 3/4H
- G 03-000111 HOSE CLAMP #10
- H 09-805320 HOSE, 3/4" x 85"

- 1 09-805345.....5/16" ABRASION RESIST. HOSE x 15' [CUT TO FIT]
- 2 03-000065.....HOSE CLAMP
- 3 56-501880.....BRACKET, FUEL PUMP
- 4 42-902311.....FUEL FILTER
- 5 41-809132.....ELECTRIC FUEL PUMP
- 6 50-501739.....COVER, FUEL PUMP BRACKET
- 7 00-000055.....SCREW, 1/4-20 x 3/4"
- 8 02-000038.....LOCKWASHER, 1/4"
- 9 00-000070.....SCREW, 1/4-20 x 1/2"
- 10 09-805417.....FUEL HOSE, 5/16 x 3-1/2"
- 11 31-900017.....CORD CONNECTOR
- 12 02-000066.....FLATWASHER, 1/4"
- 13 01-000037.....NUT, 1/4-20"
- 14 00-000078.....SCREW, 1/4-20 x 1"
- 15 43-807506.....GROMMET

**EXTERNAL
ELECTRIC
FUEL PUMP
ASSEMBLY**
KIT #66-945201

* For installation instructions,
see page 17 in this manual.

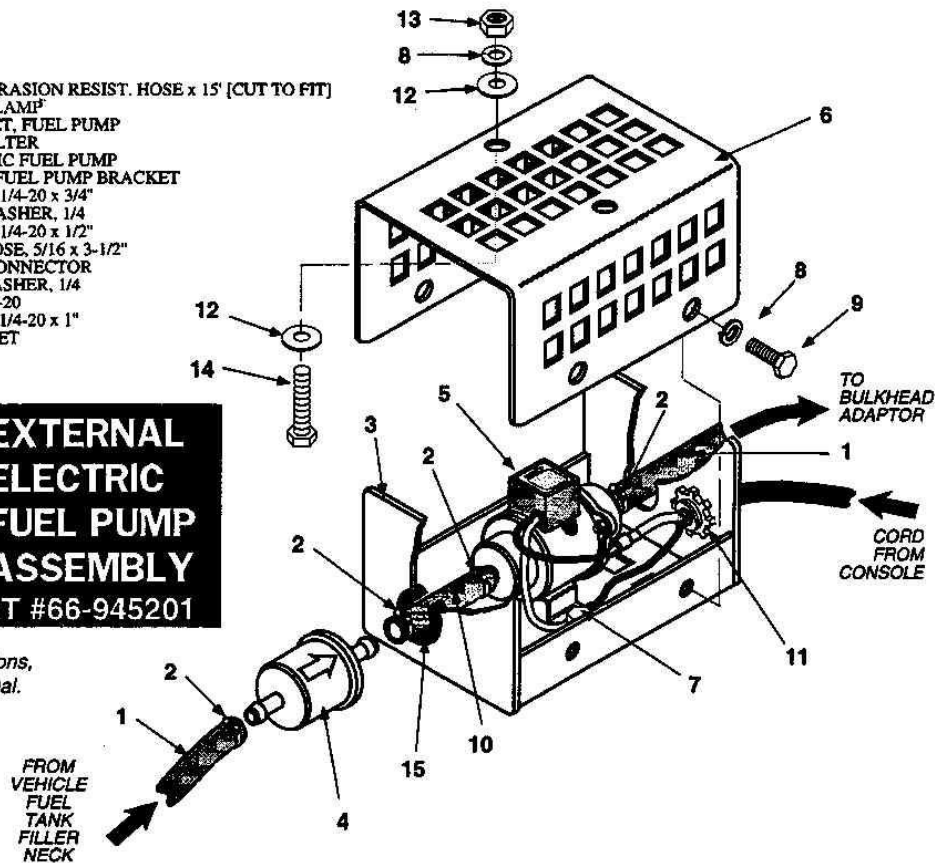

**FORD FUEL LINE
INSTALLATION KIT**
#66-945171

* For installation instructions, see
page 15 in this manual.

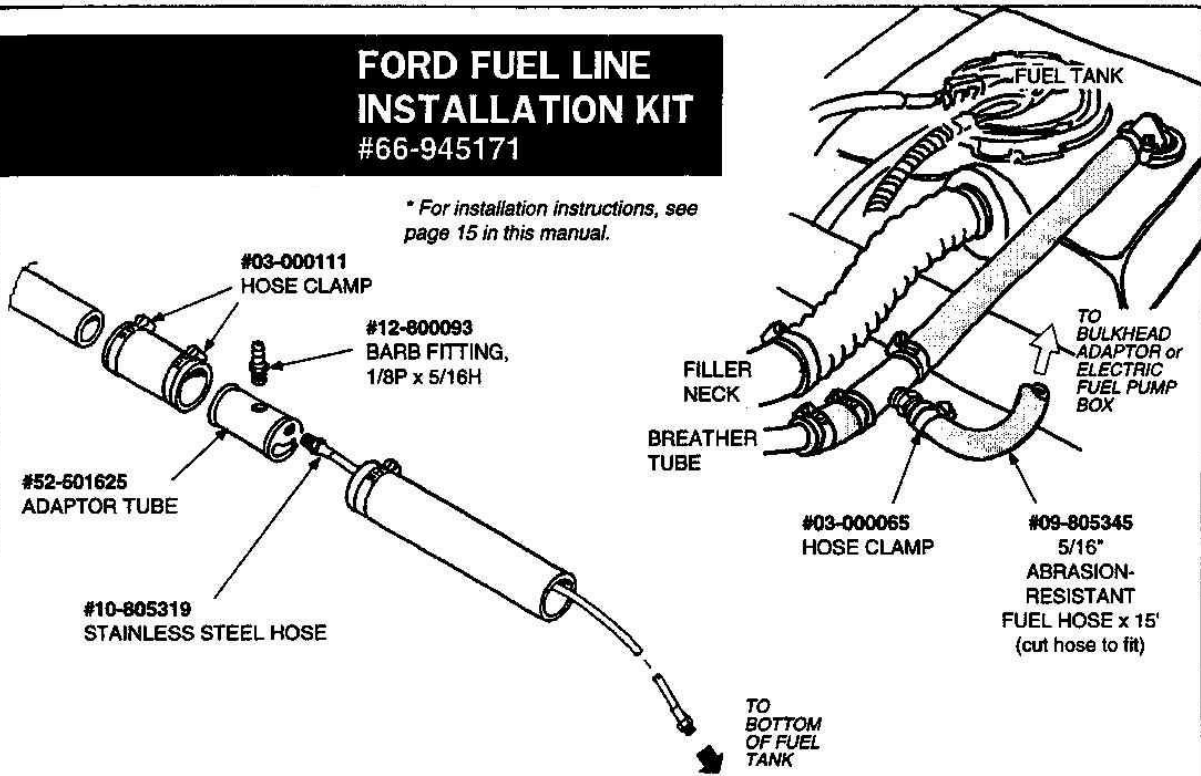

HOSE ACCESSORIES

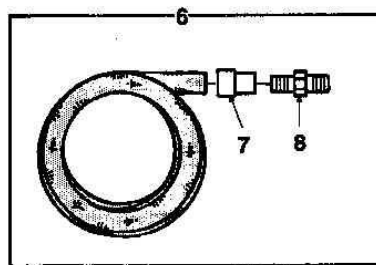
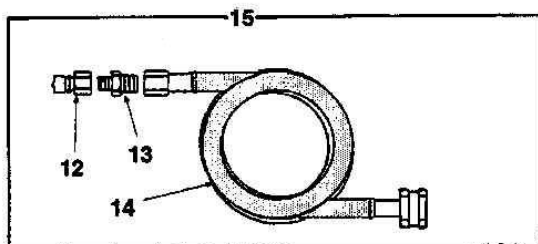
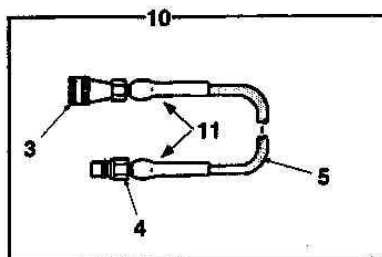
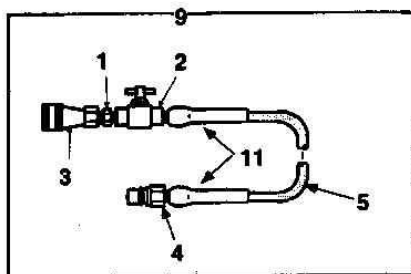

- 1 11-800029.....HEX NIPPLE, 1/4
- 2 15-808012.....BALL VALVE, 1/4
- 2A 43-810014.....O-RING [1], 1/4 BALL VALVE
- 2B 43-810019.....O-RING [2], 1/4 BALL VALVE
- 3 13-806001.....DISCONNECT, 1/4F
- 4 13-806000.....DISCONNECT, 1/4M
- 5 10-805077.....HOSE ASSEMBLY x 50' W/O DISCONNECTS OR VALVE
- 6 10-805060.....VACUUM HOSE x 50' W/ CUFFS
- 7 08-805147.....CUFF, VACUUM HOSE
- 8 12-800078.....CONNECTOR
- 9 10-805108.....HOSE ASSY, 50' W/ VALVE & DISCONNECTS
- 10 10-805122.....HOSE ASSY, 50' W/ DISCONNECTS
- 11 08-805155.....VINYL BEND GUARD
- 12 13-806009.....DISCONNECT, 3/8M
- 13 11-800354.....HEX NIPPLE, 1/2 x 3/8
- 14 10-805157.....WATER HOSE ASSY x 50'
- 15 10-805295.....WATER HOSE ASSY x 50' W/ DISCONNECT

CARPET WAND ASSEMBLY
#60-950459--95015 TIP

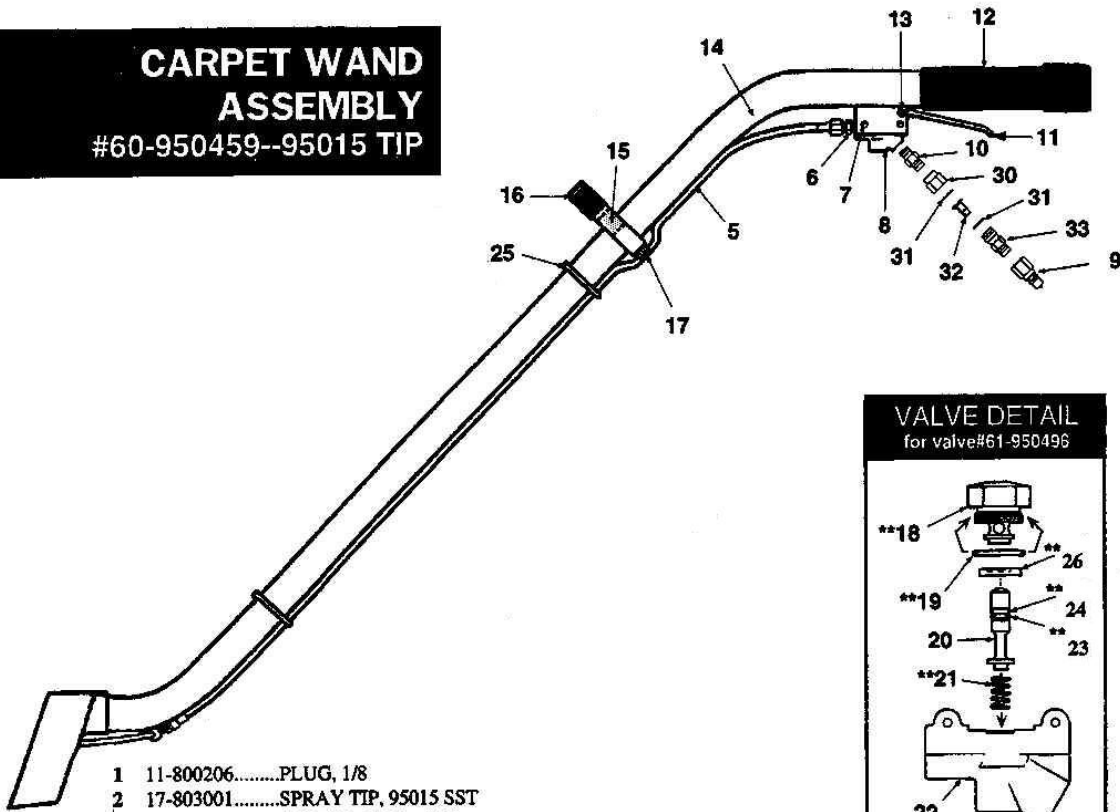

- 1 11-800206.....PLUG, 1/8
- 2 17-803001.....SPRAY TIP, 95015 SST
- 3 00-000071.....SCREW, 10-24 x 1/2"
- 4 56-501967.....MANIFOLD, TUBE ASSEMBLY
- 5 10-805387.....HOSE, 3/16 SST x 44"
- 6 12-800060.....CONNECTOR, 1/4P x 1/4T
- 7 00-000317.....SCREW, 10-32 x 1-1/4
- 8 61-950496.....VALVE
- 9 13-806000.....DISCONNECT, 1/4M
- 10 11-800029.....HEX NIPPLE, 1/4
- 11 52-501619.....LEVER
- 12 09-805359.....SLEEVE
- 13 00-000068.....SCREW, 10-32 x 1-1/4"
- 13A 01-000019.....LOCKNUT, 10-32
- 14 56-501940.....WAND
- 15 52-501569.....HOLD-DOWN, HANDLE
- 16 52-501568.....HANDLE
- 17 00-000282.....SCREW, HANDLE
- 18 16-808229.....STEM HOLDER, VALVE
- 19 43-810063.....O-RING, VALVE
- 20 16-808189.....STEM, VALVE
- 21 16-808190.....SPRING, VALVE
- 22 52-501590.....BODY, VALVE
- 23 43-810062.....O-RING, VALVE
- 24 43-810064.....BACK-UP RING, VALVE
- 25 04-000053.....NYLON TIE
- 26 16-808228.....SEAT, VALVE
- 27 56-501966.....MANIFOLD, LEFT
- 28 12-800322.....CONNECTOR, 1/8P x 1/4 COMPRESSION
- 29 56-501986.....MANIFOLD, RIGHT
- 30 17-803036.....CONNECTOR, F
- 31 17-803006.....NYLON WASHER
- 32 14-806512.....STRAINER, JET 50 MESH
- 33 17-803010.....CONNECTOR, M

NOT SHOWN 48-941225.....WAND DECAL

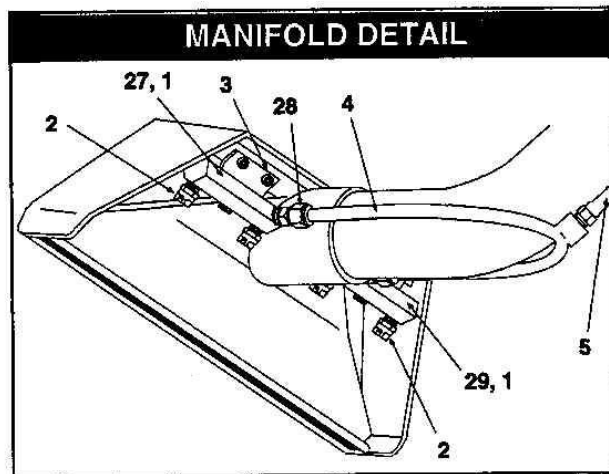
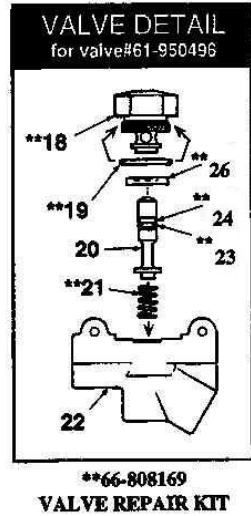

UPHOLSTERY TOOL #60-950422

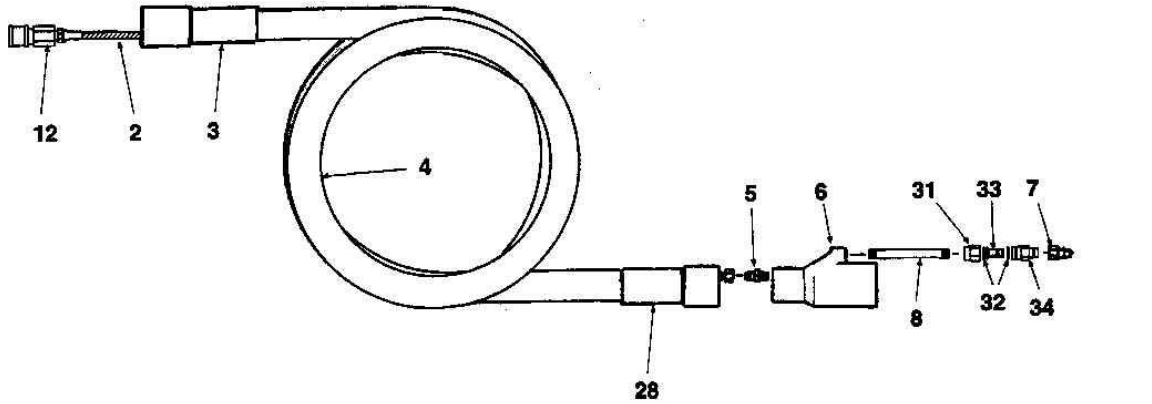

- 1 13-806030.....DISCONNECT, 1/8M
- 2 10-805347.....HOSE, 3/16 SST x 120-1/2"
- 3 08-805243.....CUFF, SWIVEL
- 4 09-805131.....VACUUM HOSE, 1-1/4 x 10'
- 5 12-800065.....CONNECTOR, 1/8P x 1/4T
- 6 52-501585.....COUPLER
- 7 13-806000.....DISCONNECT, 1/4M
- 8 11-800404.....NIPPLE, 1/4 x 5" SST
- 9 52-501624.....VACUUM ADJUSTER
- 9A 04-000282.....SPRING, VACUUM ADJ
- 9B 00-000310.....SCREW, VACUUM ADJ
- 10 52-501842.....TOOL BODY
- 11 10-805348.....HOSE, 3/16 SST x 5-1/2"
- 12 13-806023.....DISCONNECT, 1/8F
- 13 58-500639.....TRIGGER
- 14 61-950570.....VALVE ASSEMBLY
- 15 00-000307.....SCREW, 6-32 x 3/8"
- 16 00-000306.....SCREW, 6-32 x 1"
- 17 43-807513.....GASKET
- 18 52-501623.....BODY, VALVE
- 19 17-803033.....SPRAY TIP, 80015 SST
- 20 16-808190.....SPRING, VALVE
- 21 16-808189.....STEM, VALVE
- 22 43-810062.....O-RING, VALVE
- 23 43-810064.....BACK UP RING, VALVE
- 24 16-808228.....SEAT, VALVE
- 25 43-810063.....O-RING, VALVE
- 26 16-808229.....HOLDER, VALVE
- 27 00-000076.....SET SCREW
- 28 08-805138.....CUFF, 1-1/4 x 1-1/2
- 29 43-810016.....O-RING, ADJ. KNOB
- 30 52-501626.....KNOB, ADJUSTING
- 31 17-803036.....COVER
- 32 17-803006.....WASHER
- 33 14-806512.....FILTER
- 34 17-803010.....BODY

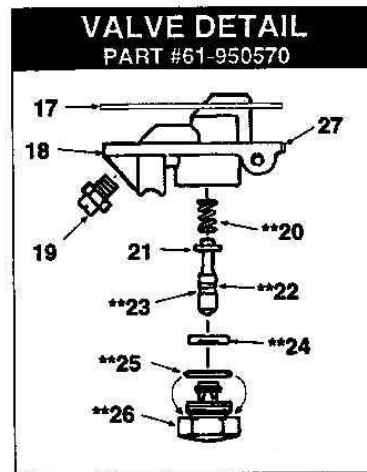
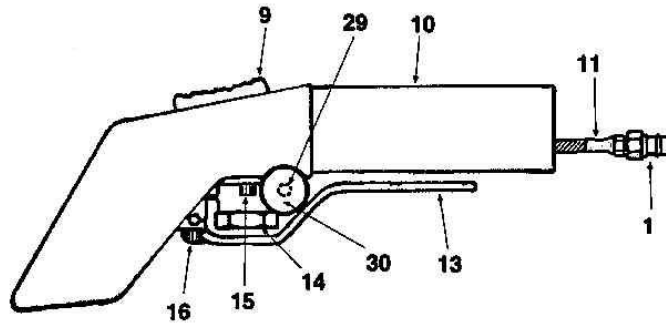

**66-808169
VALVE REPAIR KIT

STAIR TOOL ASSEMBLY

#60-950421--LONG
#60-950450--SHORT

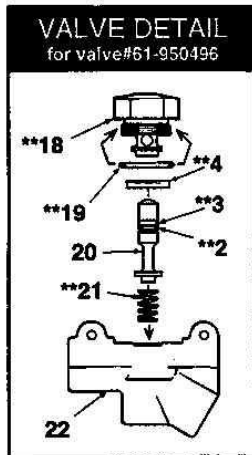
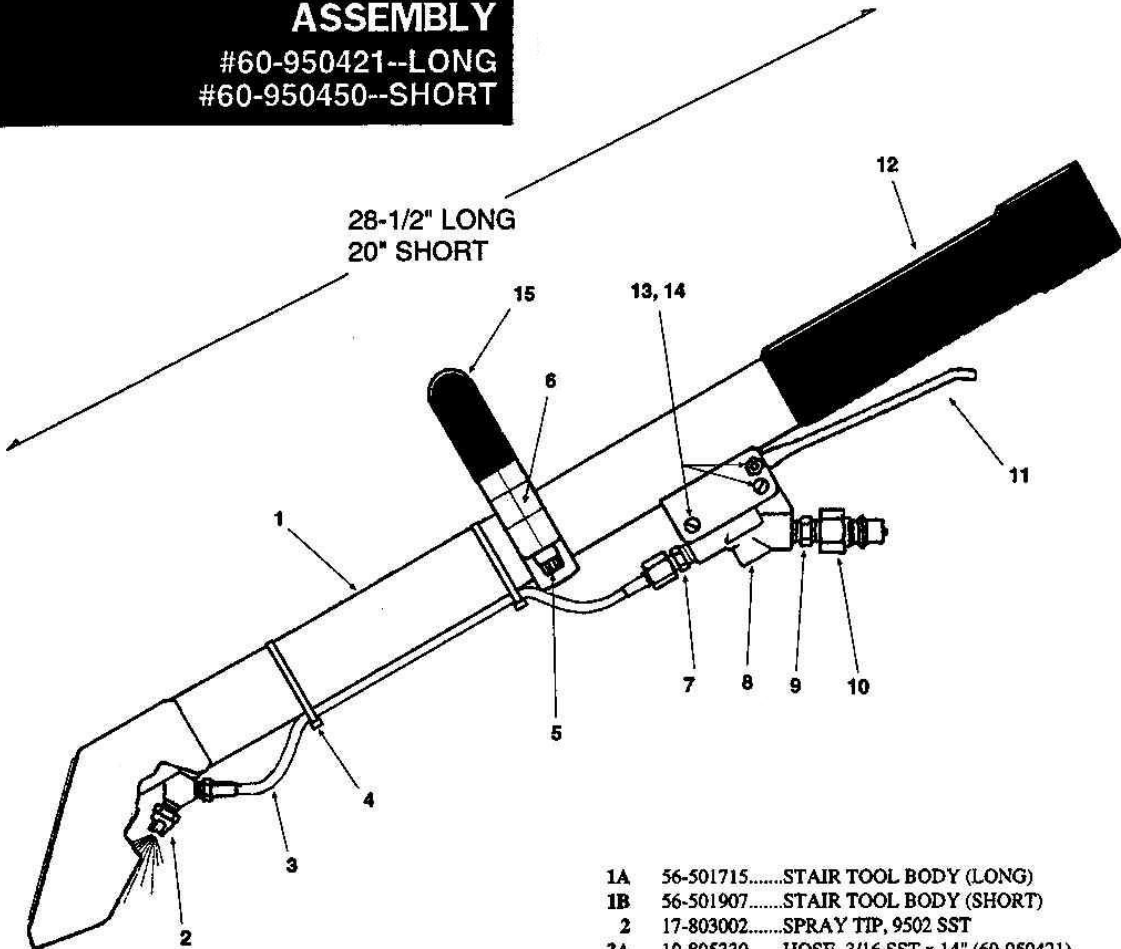

**66-808169
VALVE REPAIR KIT

- 1A 56-501715.....STAIR TOOL BODY (LONG)
- 1B 56-501907.....STAIR TOOL BODY (SHORT)
- 2 17-803002.....SPRAY TIP, 9502 SST
- 3A 10-805330.....HOSE, 3/16 SST x 14" (60-950421)
- 3B 10-805397.....HOSE, 3/16 SST x 7-1/2" (60-950450)
- 4 04-000053.....NYLON TIE
- 5 00-000282.....SCREW, 1/4 x 1-1/4"
- 6 52-501577.....HOLD-DOWN, HANDLE
- 7 12-800060.....CONNECTOR, 1/4P x 1/4T
- 8 61-950496.....VALVE
- 9 11-800029.....HEX NIPPLE, 1/4
- 10 13-806000.....DISCONNECT, 1/4M
- 11 52-501619.....TRIGGER, VALVE
- 12 09-805359.....GRIP SLEEVE
- 13 00-000317.....SCREW, 10-32 x 1-1/4
- 14 01-000241.....LOCKNUT, 10-32
- 15 52-501576.....BODY, HANDLE
- 16 16-808229.....CAP, VALVE
- 17 43-810063.....O-RING, VALVE
- 18 43-810064.....BACK-UP RING, VALVE
- 19 43-810062.....O-RING, VALVE
- 20 16-808189.....STEM, VALVE
- 21 16-808190.....SPRING, VALVE
- 22 16-808228.....SEAT, VALVE
- 23 52-501590.....BODY, VALVE